



Lesson 21: Surface Area

Student Outcomes

- Students find the surface area of three-dimensional objects whose surface area is composed of triangles and quadrilaterals. They use polyhedron nets to understand that surface area is simply the sum of the area of the lateral faces and the area of the base(s).

Classwork

Opening Exercise (8 minutes): Surface Area of a Right Rectangular Prism

Students use prior knowledge to find the surface area of the given right rectangular prism by decomposing the prism into the plane figures that represent its individual faces. Students then discuss their methods aloud.

Opening Exercise: Surface Area of a Right Rectangular Prism

On the provided grid, draw a net representing the surfaces of the right rectangular prism (assume each grid line represents 1 inch). Then find the surface area of the prism by finding the area of the net.

There are six rectangular faces that make up the net.

The four rectangles in the center form one long rectangle that is 20 in by 3 in.

$Area = lw$

$Area = 3\text{ in} \cdot 20\text{ in}$

$Area = 60\text{ in}^2$

Two rectangles form the wings, both 6 in by 4 in.

$Area = lw$

$Area = 6\text{ in} \cdot 4\text{ in}$

$Area = 24\text{ in}^2$

The area of both wings is $2(24\text{ in}^2) = 48\text{ in}^2$.

The total area of the net is

$A = 60\text{ in}^2 + 48\text{ in}^2 = 108\text{ in}^2$

The net represents all the surfaces of the rectangular prism, so its area is equal to the surface area of the prism. The surface area of the right rectangular prism is 108 in^2 .

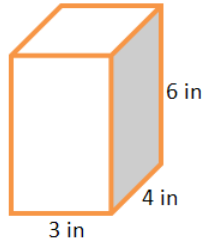

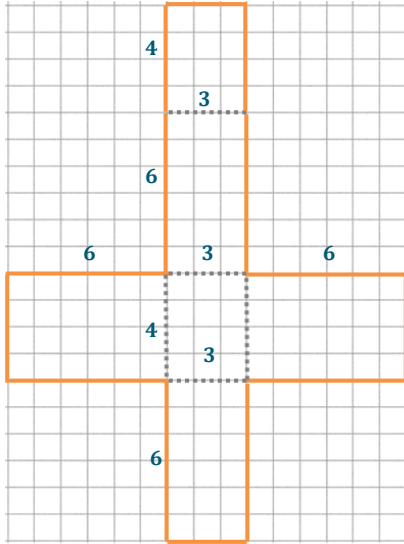

Scaffolding:

Students may need to review the meaning of the term *net* from Grade 6. Prepare a solid right rectangular prism such as a wooden block and a paper net covering the prism to model where a net comes from.



Note to teacher: Students may draw any of the variations of nets for the given prism.

Discussion (3 minutes)

- What other ways could we have found the surface area of the rectangular prism?
 - *Surface area formula:* $SA = 2lw + 2lh + 2wh$
 $SA = 2(3 \text{ in} \cdot 4 \text{ in}) + 2(3 \text{ in} \cdot 6 \text{ in}) + 2(4 \text{ in} \cdot 6 \text{ in})$
 $SA = 24 \text{ in}^2 + 36 \text{ in}^2 + 48 \text{ in}^2$
 $SA = 108 \text{ in}^2$
 - *Find the areas of each individual rectangular face:*

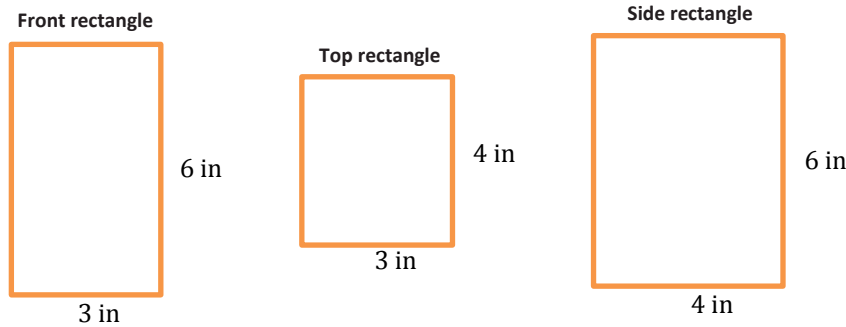

- *Area = length × width*

$A = 6 \text{ in} \times 3 \text{ in}$	$A = 4 \text{ in} \times 3 \text{ in}$	$A = 6 \text{ in} \times 4 \text{ in}$
$A = 18 \text{ in}^2$	$A = 12 \text{ in}^2$	$A = 24 \text{ in}^2$

There are two of each face, so $SA = 2(18 \text{ in}^2 + 12 \text{ in}^2 + 24 \text{ in}^2)$
 $SA = 2(54 \text{ in}^2)$
 $SA = 108 \text{ in}^2$

Discussion (6 minutes): Terminology

A right prism can be described as a solid with two “end” faces (called its *bases*) that are exact copies of each other and rectangular faces that join corresponding edges of the bases (called *lateral faces*).

- Are the bottom and top faces of a right rectangular prism the bases of the prism?
 - *Not always. Any of its opposite faces can be considered bases because they are all rectangles.*
- If we slice the right rectangular prism in half along a diagonal of a base (see picture), the two halves are called right triangular prisms. Why do you think they are called triangular prisms?
 - *The bases of each prism are triangles, and prisms are named by their bases.*
- Why must the triangular faces be the bases of these prisms?
 - *Because the lateral faces (faces that are not bases) of a right prism have to be rectangles.*
- Can the surface area formula for a right rectangular prism ($SA = 2lw + 2lh + 2wh$) be applied to find the surface area of a right triangular prism? Why or why not?
 - *No, because each of the terms in the surface area formula represents the area of a rectangular face. A right triangular prism has bases that are triangular, not rectangular.*

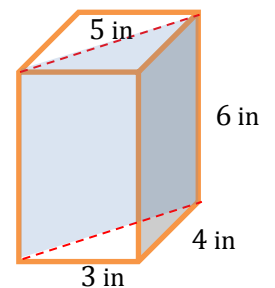

Exercise 1 (8 minutes)

Students find the surface area of the right triangular prism to determine the validity of a given conjecture.

Exercise 1

Marcus thinks that the surface area of the right triangular prism will be half that of the right rectangular prism and wants to use the modified formula $SA = \frac{1}{2}(2lw + 2lh + 2wh)$. Do you agree or disagree with Marcus? Use nets of the prisms to support your argument.

The surface area of the right rectangular prism is 108 in^2 , so Marcus believes the surface areas of each right triangular prism is 54 in^2 .

Students can make comparisons of the area values depicted in the nets of the prisms and can also compare the physical areas of the nets either by overlapping the nets on the same grid or using a transparent overlay.

MP.3

The net of the right triangular prism has one less face than the right rectangular prism. Two of the rectangular faces on the right triangular prism (rectangular regions 1 and 2 in the diagram) are the same faces from the right rectangular prism, so they are the same size. The areas of the triangular bases (triangular regions 3 and 4 in the diagram) are half the area of their corresponding rectangular faces of the right rectangular prism. These four faces of the right triangular prism make up half the surface area of the right rectangular prism before considering the fifth face, so no, Marcus is incorrect.

The areas of rectangular faces 1 and 2, plus the areas of the triangular regions 3 and 4 is 54 in^2 . The last rectangular region has an area of 30 in^2 . The total area of the net is $54 + 30 = 84 \text{ in}^2$, which is far more than half the surface area of the right rectangular prism.

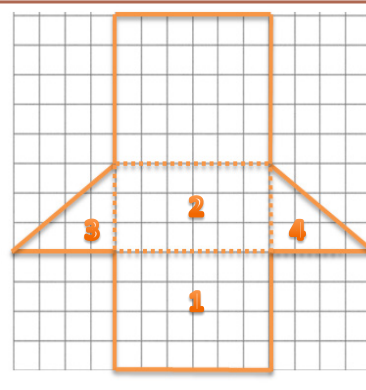

Use a transparency to show students how the nets overlap where the lateral faces together form a longer rectangular region and the bases are represented by “wings” on either side of that triangle. You may want to use student work for this if you see a good example. Use this setup in the following discussion.

Discussion (5 minutes)

- The surface area formula ($SA = 2lw + 2lh + 2wh$) for a right rectangular prism cannot be applied to a right triangular prism. Why?
 - *The formula adds the areas of six rectangular faces. A right triangular prism only has four rectangular faces and also has two triangular faces (bases).*
- The area formula for triangles is $\frac{1}{2}$ the formula for the area of rectangles or parallelograms. Can the surface area of a triangular prism be obtained by dividing the surface area formula for a right rectangular prism by 2? Explain.
 - *No. The right triangular prism in the above example had more than half the surface area of the right rectangular prism that it was cut from. If this occurs in one case, then it must occur in others as well.*

- If you compare the nets of the right rectangular prism and the right triangular prism, what do the nets seem to have in common? (Hint: What do all right prisms have in common? Answer: Rectangular lateral faces.)
 - *Their lateral faces form a larger rectangular region and the bases are attached to the side of that rectangle like “wings”.*
- Will this commonality always exist in right prisms? How do you know?
 - *Yes! Right prisms must have rectangular lateral faces. If we align all the lateral faces of a right prism in a net, they can always form a larger rectangular region because they all have the same height as the prism.*
- How do we determine the total surface area of the prism?
 - *Add the total area of the lateral faces and the areas of the bases*
If we let LA represent the lateral area and let B represent the area of a base, then the surface area of a right prism can be found using the formula:
 $SA = LA + 2B$

Scaffolding:

The teacher may need to assist students at finding the commonality between the nets of right prisms by showing examples of various right prisms and the fact that they all have rectangular lateral faces. The rectangular faces may be described as “connectors” between the bases of a right prism.

Example 1 (6 minutes): Lateral Area of a Right Prism

Students find the lateral areas of right prisms and recognize the pattern of multiplying the height of the right prism (the distance between its bases) by the perimeter of the prism’s base.

Example 1

A right triangular prism, a right rectangular prism, and a right pentagonal prism are pictured below, and all have equal heights of h .

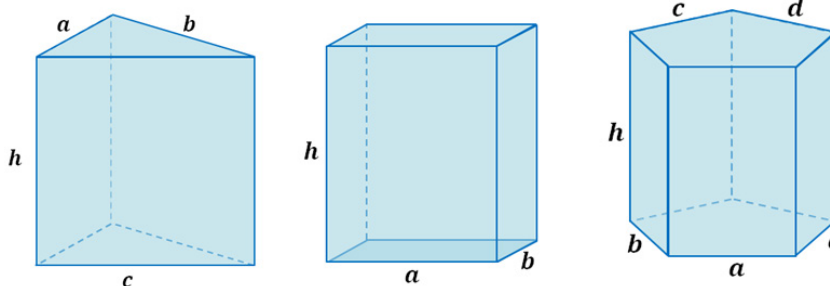

- a. Write an expression that represents the lateral area of the right triangular prism as the sum of the areas of its lateral faces.

$$a \cdot h + b \cdot h + c \cdot h$$

- b. Write an expression that represents the lateral area of the right rectangular prism as the sum of the areas of its lateral faces.

$$a \cdot h + b \cdot h + a \cdot h + b \cdot h$$

MP.8

MP.8

- c. Write an expression that represents the lateral area of the right pentagonal prism as the sum of the areas of its lateral faces.

$$a \cdot h + b \cdot h + c \cdot h + d \cdot h + e \cdot h$$

- d. What value appears often in each expression and why?

h; Each prism has a height of h, and therefore each lateral face has a height of h.

- e. Rewrite each expression in factored form using the distributive property and the height of each lateral face.

$$h(a + b + c)$$

$$h(a + b + a + b)$$

$$h(a + b + c + d + e)$$

- f. What do the parentheses in each case represent with respect to the right prisms?

$$h \overbrace{(a + b + c)}^{\text{perimeter}}$$

$$h \overbrace{(a + b + a + b)}^{\text{perimeter}}$$

$$h \overbrace{(a + b + c + d + e)}^{\text{perimeter}}$$

The perimeter of the base of the corresponding prism.

- g. How can we generalize the lateral area of a right prism into a formula that applies to all right prisms?

If LA represents the lateral area of a right prism, P represents the perimeter of the right prism's base, and h represents the distance between the right prism's bases, then:

$$LA = P_{\text{base}} \cdot h$$

Scaffolding:

Example 1 can be explored further by assigning numbers to represent the lengths of the sides of the bases of each prism. If students represent the lateral area as the sum of the areas of the lateral faces without evaluating, the common factor in each term will be evident and can then be factored out to reveal the same relationship.

Closing (5 minutes)

The vocabulary below contains the precise definitions of the visual/colloquial descriptions used in the lesson. Please read through the definitions aloud with your students, asking them questions that compare the visual/colloquial descriptions used in the lesson with the precise definitions.

Relevant Vocabulary

Right Prism: Let E and E' be two parallel planes. Let B be a triangular or rectangular region or a region that is the union of such regions in the plane E . At each point P of B , consider the segment PP' perpendicular to E , joining P to a point P' of the plane E' . The union of all these segments is a solid called a *right prism*.

There is a region B' in E' that is an exact copy of the region B . The regions B and B' are called the base faces (or just bases) of the prism. The rectangular regions between two corresponding sides of the bases are called lateral faces of the prism. In all, the boundary of a right rectangular prism has 6 *faces*: 2 base faces and 4 lateral faces. All adjacent faces intersect along segments called edges (base edges and lateral edges).

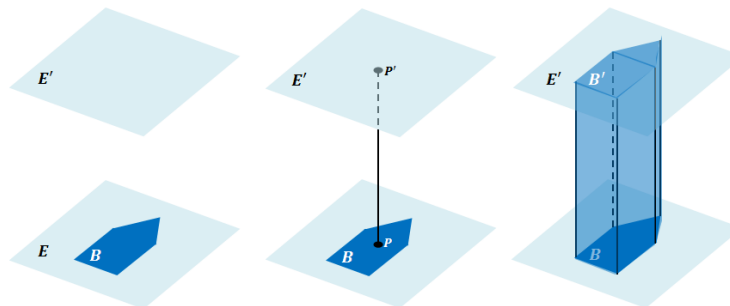

Cube: A *cube* is a right rectangular prism all of whose edges are of equal length.

Surface: The *surface of a prism* is the union of all of its faces (the base faces and lateral faces).

Net (description): A *net* is a two dimensional diagram of the surface of a prism.

1. Why are the lateral faces of right prisms always rectangular regions?

Because along a base edge, the line segments PP' are always perpendicular to the edge, forming a rectangular region.

2. What is the name of the right prism whose bases are rectangles?

Right rectangular prism.

3. How does this definition of right prism include the interior of the prism?

The union of all the line segments fills out the interior.

Lesson Summary

The surface area of a right prism can be obtained by adding the areas of the lateral faces to the area of the bases. The formula for the surface area of a right prism is $SA = LA + 2B$, where SA represents surface area of the prism, LA represents the area of the lateral faces, and B represents the area of one base. The lateral area LA can be obtained by multiplying the perimeter of the base of the prism times the height of the prism.

Exit Ticket (4 minutes)

Name _____

Date _____

Lesson 21: Surface Area

Exit Ticket

Find the surface area of the right trapezoidal prism. Show all necessary work.

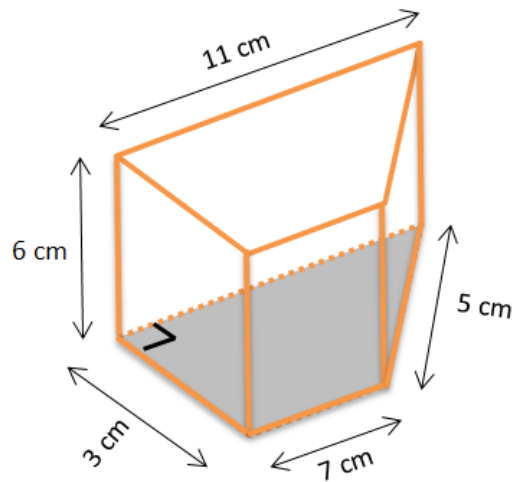

Exit Ticket Sample Solutions

Find the surface area of the right trapezoidal prism. Show all necessary work.

$$SA = LA + 2B$$

$$LA = P \cdot h$$

$$LA = (3 + 7 + 5 + 11) \text{ cm} \cdot 6 \text{ cm}$$

$$LA = 26 \text{ cm} \cdot 6 \text{ cm}$$

$$LA = 156 \text{ cm}^2$$

Each base consists of a 3 cm by 7 cm rectangle and right triangle with a base of 3 cm and a height of 4 cm. Therefore, the area of each base:

$$B = A_r + A_t$$

$$B = lw + \frac{1}{2}bh$$

$$B = (7 \text{ cm} \cdot 3 \text{ cm}) + \left(\frac{1}{2} \cdot 3 \text{ cm} \cdot 4 \text{ cm}\right)$$

$$B = 21 \text{ cm}^2 + 6 \text{ cm}^2$$

$$B = 27 \text{ cm}^2$$

$$SA = LA + 2B$$

$$SA = 156 \text{ cm}^2 + 2(27 \text{ cm}^2)$$

$$SA = 156 \text{ cm}^2 + 54 \text{ cm}^2$$

$$SA = 210 \text{ cm}^2$$

The surface of the right trapezoidal prism is 210 cm².

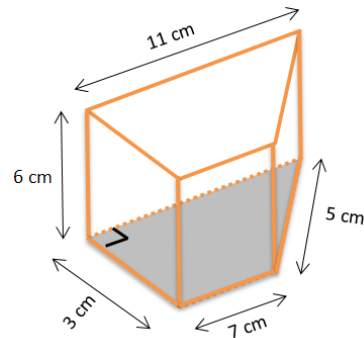

Problem Set Sample Solutions

1. For each of the following nets, highlight the perimeter of the lateral area, draw the solid represented by the net, indicate the type of solid, and then find the solid's surface area.

a.

Right rectangular prism.

$$SA = LA + 2B$$

$$LA = P \cdot h$$

$$LA = \left(2\frac{1}{2} \text{ cm} + 7\frac{1}{2} \text{ cm} + 2\frac{1}{2} \text{ cm} + 7\frac{1}{2} \text{ cm}\right) \cdot 5 \text{ cm}$$

$$LA = 20 \text{ cm} \cdot 5 \text{ cm}$$

$$LA = 100 \text{ cm}^2$$

$$SA = 100 \text{ cm}^2 + 2\left(\frac{75}{4} \text{ cm}^2\right)$$

$$SA = 100 \text{ cm}^2 + 37.5 \text{ cm}^2 = 137.5 \text{ cm}^2$$

$$B = lw$$

$$B = 2\frac{1}{2} \text{ cm} \cdot 7\frac{1}{2} \text{ cm}$$

$$B = \frac{5}{2} \text{ cm} \cdot \frac{15}{2} \text{ cm}$$

$$B = \frac{75}{4} \text{ cm}^2$$

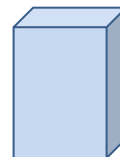
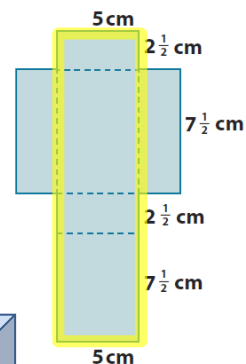

(3-Dimensional Form)

The surface area of the right rectangular prism is 137.5 cm².

b. $SA = LA + 2B$

$LA = P \cdot h$

$LA = (10 \text{ in} + 8 \text{ in} + 10 \text{ in}) \cdot 12 \text{ in}$

$LA = 28 \text{ in} \cdot 12 \text{ in}$

$LA = 336 \text{ in}^2$

$SA = 336 \text{ in}^2 + 2\left(36\frac{4}{5} \text{ in}^2\right)$

$SA = 336 \text{ in}^2 + \left(72 + \frac{8}{5}\right) \text{ in}^2$

$SA = 408 \text{ in}^2 + 1\frac{3}{5} \text{ in}^2$

$SA = 409\frac{3}{5} \text{ in}^2$

The surface area of the right triangular prism is $409\frac{3}{5} \text{ in}^2$.

$B = \frac{1}{2}bh$

$B = \frac{1}{2}(8 \text{ in})\left(9\frac{1}{5} \text{ in}\right)$

$B = 4 \text{ in}\left(9\frac{1}{5} \text{ in}\right)$

$B = \left(36 + \frac{4}{5}\right) \text{ in}^2 = 36\frac{4}{5} \text{ in}^2$

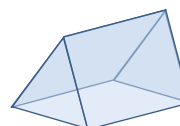
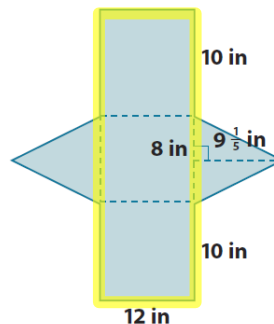

(3-Dimensional Form)

2. Given a cube with edges that are $\frac{3}{4}$ inch long:

a. Find the surface area of the cube.

$SA = 6s^2$

$SA = 6\left(\frac{3}{4} \text{ in}\right)^2$

$SA = 6\left(\frac{3}{4} \text{ in}\right) \cdot \left(\frac{3}{4} \text{ in}\right)$

$SA = 6\left(\frac{9}{16} \text{ in}^2\right)$

$SA = \frac{27}{8} \text{ in}^2 = 3\frac{3}{8} \text{ in}^2$

b. Joshua makes a scale drawing of the cube using a scale factor of 4. Find the surface area of the cube that Joshua drew.

$\frac{3}{4} \text{ in} \cdot 4 = 3 \text{ in}$; The edge lengths of Joshua's drawing would be 3 inches.

$SA = 6(3 \text{ in})^2$

$SA = 6(9 \text{ in}^2) = 54 \text{ in}^2$

c. What is the ratio of the surface area of the scale drawing to the surface area of the actual cube, and how does the value of the ratio compare to the scale factor?

$54 \div 3\frac{3}{8}$

$54 \div \frac{27}{8}$

$54 \cdot \frac{8}{27}$

$2 \cdot 8 = 16$. The ratios of the surface area of the scale drawing to the surface area of the actual cube is 16:1. The value of the ratio is 16. The scale factor of the drawing is 4, and the value of the ratio of the surface area of the drawing to the surface area of the actual cube is $4^2 = 16$.

3. Find the surface area of each of the following prisms using the formula $SA = LA + 2B$.

a. $SA = LA + 2B$

$LA = P \cdot h$

$LA = (12\frac{1}{2} \text{ mm} + 10 \text{ mm} + 7\frac{1}{2} \text{ mm}) \cdot 15 \text{ mm}$

$LA = 30 \text{ mm} \cdot 15 \text{ mm} = 450 \text{ mm}^2$

$B = \frac{1}{2}bh$

$SA = 450 \text{ mm}^2 + 2(\frac{75}{2} \text{ mm}^2)$

$B = \frac{1}{2} \cdot (7\frac{1}{2} \text{ mm}) \cdot (10 \text{ mm})$

$SA = 450 \text{ mm}^2 + 75 \text{ mm}^2$

$B = \frac{1}{2} \cdot (70 + 5) \text{ mm}^2$

$SA = 525 \text{ mm}^2$

$B = \frac{1}{2} \cdot 75 \text{ mm}^2 = \frac{75}{2} \text{ mm}^2$

The surface area of the prism is 525 mm^2 .

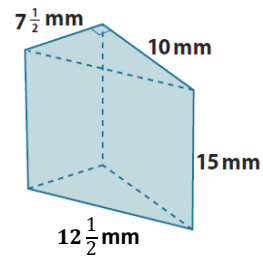

b. $SA = LA + 2B$

$LA = P \cdot h$

$B = \frac{1}{2}bh$

$LA = (9\frac{3}{25} \text{ in} + 6\frac{1}{2} \text{ in} + 4 \text{ in}) \cdot 5 \text{ in}$

$B = \frac{1}{2} \cdot 9\frac{3}{25} \text{ in} \cdot 2\frac{1}{2} \text{ in}$

$LA = (\frac{228}{25} \text{ in} + \frac{13}{2} \text{ in} + 4 \text{ in}) \cdot 5 \text{ in}$

$B = \frac{1}{2} \cdot \frac{228}{25} \text{ in} \cdot \frac{5}{2} \text{ in}$

$LA = (\frac{456}{50} \text{ in} + \frac{325}{50} \text{ in} + \frac{200}{50} \text{ in}) \cdot 5 \text{ in}$

$B = \frac{1,140}{100} \text{ in}^2$

$LA = (\frac{981}{50} \text{ in}) \cdot 5 \text{ in}$

$B = 11\frac{2}{5} \text{ in}^2$

$LA = \frac{49,050}{50} \text{ in}^2$

$2B = 2 \cdot 11\frac{2}{5} \text{ in}^2$

$LA = 98\frac{1}{10} \text{ in}^2$

$2B = 22\frac{4}{5} \text{ in}^2$

$SA = LA + 2B$

$SA = 98\frac{1}{10} \text{ in}^2 + 22\frac{4}{5} \text{ in}^2$

$SA = 120\frac{9}{10} \text{ in}^2$

The surface area of the prism is $120\frac{9}{10} \text{ in}^2$.

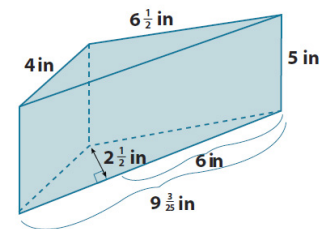

c. $SA = LA + 2B$

$LA = P \cdot h$

$LA = \left(\frac{1}{8} in + \frac{1}{2} in + \frac{1}{8} in + \frac{1}{4} in + \frac{1}{2} in + \frac{1}{4} in\right) \cdot 2 in$

$LA = \left(1\frac{3}{4} in\right) \cdot 2 in$

$LA = 2 in^2 + 1\frac{1}{2} in^2$

$LA = 3\frac{1}{2} in^2$

$SA = 3\frac{1}{2} in^2 + 2\left(\frac{1}{8} in^2\right)$

$SA = 3\frac{1}{2} in^2 + \frac{1}{4} in^2$

$SA = 3\frac{2}{4} in^2 + \frac{1}{4} in^2$

$SA = 3\frac{3}{4} in^2$

The surface area of the prism is $3\frac{3}{4} in^2$.

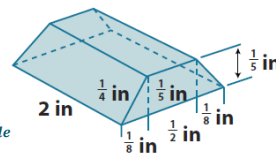

$b = A_{rectangle} + 2A_{triangle}$

$b = \left(\frac{1}{2} in \cdot \frac{1}{5} in\right) + 2 \cdot \frac{1}{2} \left(\frac{1}{8} in \cdot \frac{1}{5} in\right)$

$b = \left(\frac{1}{10} in^2\right) + \left(\frac{1}{40} in^2\right)$

$b = \frac{1}{10} in^2 + \frac{1}{40} in^2$

$b = \frac{4}{40} in^2 + \frac{1}{40} in^2$

$b = \frac{5}{40} in^2$

$b = \frac{1}{8} in^2$

d. $SA = LA + 2B$

$LA = P \cdot h$

$LA = (13 cm + 13 cm + 8.6 cm + 8.6 cm) \cdot 2\frac{1}{4} cm$

$LA = (26 + 17.2) cm \cdot 2\frac{1}{4} cm$

$LA = (43.2) cm \cdot 2\frac{1}{4} cm$

$LA = (86.4 + 10.8) cm^2$

$LA = 97.2 cm^2$

$SA = LA + 2B$

$SA = 97.2 cm^2 + 2(95 cm^2)$

$SA = 97.2 cm^2 + 190 cm^2$

$SA = 287.2 cm^2$

The surface area of the prism is $287.2 cm^2$.

$B = \frac{1}{2} (10 cm \cdot 7 cm) + \frac{1}{2} (12 cm \cdot 10 cm)$

$B = \frac{1}{2} (70 cm^2 + 120 cm^2)$

$B = \frac{1}{2} (190 cm^2)$

$B = 95 cm^2$

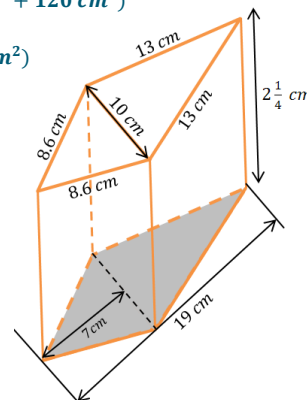

4. A cube has a volume of $64 m^3$. What is the cube's surface area?

A cube's length, width, and height must be equal. $64 = 4 \cdot 4 \cdot 4 = 4^3$, so the length, width, and height of the cube are all 4 m.

$SA = 6s^2$

$SA = 6(4 m)^2$

$SA = 6(16 m^2)$

$SA = 96 m^2$

5. The height of a right rectangular prism is $4\frac{1}{2}$ ft. The length and width of the prism's base are 2 ft and $1\frac{1}{2}$ ft. Use the formula $SA = LA + 2B$ to find the surface area of the right rectangular prism.

$$SA = LA + 2B$$

$$LA = P \cdot h$$

$$b = lw$$

$$SA = LA + 2b$$

$$LA = (2 \text{ ft} + 2 \text{ ft} + 1\frac{1}{2} \text{ ft} + 1\frac{1}{2} \text{ ft}) \cdot 4\frac{1}{2} \text{ ft}$$

$$b = 2 \text{ ft} \cdot 1\frac{1}{2} \text{ ft}$$

$$SA = 31\frac{1}{2} \text{ ft}^2 + 2(3 \text{ ft}^2)$$

$$LA = (2 \text{ ft} + 2 \text{ ft} + 3 \text{ ft}) \cdot 4\frac{1}{2} \text{ ft}$$

$$b = 3 \text{ ft}^2$$

$$SA = 31\frac{1}{2} \text{ ft}^2 + 6 \text{ ft}^2$$

$$LA = 7 \text{ ft} \cdot 4\frac{1}{2} \text{ ft}$$

$$SA = 37\frac{1}{2} \text{ ft}^2$$

$$LA = 28 \text{ ft}^2 + 3\frac{1}{2} \text{ ft}^2$$

$$LA = 31\frac{1}{2} \text{ ft}^2$$

The surface area of the right rectangular prism is $37\frac{1}{2} \text{ ft}^2$.

6. The surface area of a right rectangular prism is $68\frac{2}{3} \text{ in}^2$. The dimensions of its base are 3 in and 7 in. Use the formula $SA = LA + 2B$ and $LA = Ph$ to find the unknown height h of the prism.

$$SA = LA + 2B$$

$$SA = P \cdot h + 2B$$

$$68\frac{2}{3} \text{ in}^2 = 20 \text{ in} \cdot (h) + 2(21 \text{ in}^2)$$

$$68\frac{2}{3} \text{ in}^2 = 20 \text{ in} \cdot (h) + 42 \text{ in}^2$$

$$68\frac{2}{3} \text{ in}^2 - 42 \text{ in}^2 = 20 \text{ in} \cdot (h) + 42 \text{ in}^2 - 42 \text{ in}^2$$

$$26\frac{2}{3} \text{ in}^2 = 20 \text{ in} \cdot (h) + 0 \text{ in}^2$$

$$26\frac{2}{3} \text{ in}^2 \cdot \frac{1}{20 \text{ in}} = 20 \text{ in} \cdot \frac{1}{20 \text{ in}} \cdot (h)$$

$$\frac{80}{3} \text{ in}^2 \cdot \frac{1}{20 \text{ in}} = 1 \cdot h$$

$$\frac{4}{3} \text{ in} = h$$

$$h = \frac{4}{3} \text{ in} = 1\frac{1}{3} \text{ in}$$

The height of the prism is $1\frac{1}{3} \text{ in}$.

7. A given right triangular prism has an equilateral triangular base. The height of that equilateral triangle is approximately 7.1 cm. The distance between the bases is 9 cm. The surface area of the prism is $319\frac{1}{2} \text{ cm}^2$. Find the lengths of the sides of the base.

$$SA = LA + 2B$$

Let x represent the number of centimeters in each side of the equilateral triangle.

$$LA = P \cdot h$$

$$B = \frac{1}{2}lw$$

$$319\frac{1}{2} \text{ cm}^2 = LA + 2B$$

$$LA = 3(x \text{ cm}) \cdot 9 \text{ cm}$$

$$B = \frac{1}{2} \cdot (x \text{ cm}) \cdot 7.1 \text{ cm}$$

$$319\frac{1}{2} \text{ cm}^2 = 27x \text{ cm}^2 + 2(3.55x \text{ cm}^2)$$

$$LA = 27x \text{ cm}^2$$

$$B = 3.55x \text{ cm}^2$$

$$319\frac{1}{2} \text{ cm}^2 = 27x \text{ cm}^2 + 7.1x \text{ cm}^2$$

$$319\frac{1}{2} \text{ cm}^2 = 34.1x \text{ cm}^2$$

$$319\frac{1}{2} \text{ cm}^2 = 34\frac{1}{10}x \text{ cm}^2$$

$$\frac{639}{2} \text{ cm}^2 = \frac{341}{10}x \text{ cm}^2$$

$$\frac{639}{2} \text{ cm}^2 \cdot \frac{10}{341 \text{ cm}} = \frac{341}{10}x \text{ cm}^2 \cdot \frac{10}{341 \text{ cm}}$$

$$\frac{3195}{341} \text{ cm} = x$$

$$x = \frac{3195}{341} \text{ cm}$$

$$x \approx 9.4 \text{ cm}$$

The lengths of the sides of the equilateral triangles are approximately 9.4 cm each.