



Lesson 11: Volume with Fractional Edge Lengths and Unit Cubes

Cubes

Student Outcomes

- Students extend their understanding of the volume of a right rectangular prism with integer side lengths to right rectangular prisms with fractional side lengths. They apply the formula $V = l \cdot w \cdot h$ to find the volume of a right rectangular prism and use the correct volume units when writing the answer.

Lesson Notes

This lesson builds on the work done in Module 5 of Grade 5, Topics A and B. Within these topics, students determine the volume of rectangular prisms with side lengths that are whole numbers. Students fill prisms with unit cubes in addition to using the formulas $V = Bh$ and $V = l \cdot w \cdot h$ to determine the volume.

Students start their work on volume of prisms with fractional lengths so that they can continue to build an understanding of the units of volume. In addition, they must continue to build the connection between packing and filling. In the following lessons, students move from packing the prisms to using the formula.

For students who may not have been studying the common core in Grade 5, a document titled “Understanding Volume” has been attached at the end of the lesson.

Scaffolding:

Use unit cubes to help students visualize the problems in this lesson.

One way to do this would be to have students make a conjecture about how many cubes will fill the prism and then use the cubes to test their ideas.

Provide different examples of volume (electronic devices, loudness of voice), and explain that although this is the same word, the context of volume in this lesson refers to 3-dimensional figures.

Fluency Exercise (5 minutes)

Multiplication of Fractions Sprint

Classwork

Opening Exercise (3 minutes)

Please note that although scaffolding questions are provided, this Opening Exercise is an excellent chance to let students work on their own, persevering through and making sense of the problem.

Opening Exercise

Which prism will hold more $1 \text{ in.} \times 1 \text{ in.} \times 1 \text{ in.}$ cubes? How many more cubes will the prism hold?

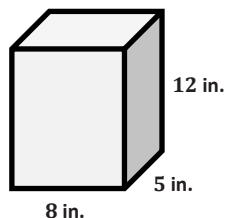
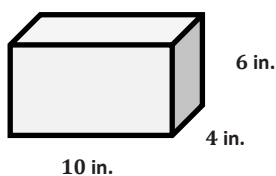

MP.1

Have students discuss their solutions with a partner.

- How many 1 in. \times 1 in. \times 1 in. cubes will fit across the bottom of the first rectangular prism?
 - 40 cubes will fit across the bottom.
- How did you determine this number?
 - Answers will vary. Students may determine how many cubes will fill the bottom layer of the prism and then decide how many layers are needed. Students that are new to the English language may need a model of what layers means in this context.
- How many layers of 1 in. \times 1 in. \times 1 in. cubes would fit inside the rectangular prism?
 - There are 6 inches in the height; therefore, 6 layers of cubes will fit inside.
- How many 1 in. \times 1 in. \times 1 in. cubes would fit across the bottom of the second rectangular prism?
 - 40 cubes will fit across the bottom.
- How many layers would you need?
 - 12 layers because the prism is 12 inches tall.
- Which rectangular prism will hold more cubes?
 - The second rectangular prism will hold more cubes.
- How did you determine this?
 - Both rectangular prisms hold the same number of cubes in one layer, but the second rectangular prism has more layers.
- How many more layers does the second rectangular prism hold?
 - 12 more layers
- How many more cubes does the second rectangular prism hold?
 - The second rectangular prism has 6 more layers than the first with 40 cubes in each layer.
 - $6 \times 40 = 240$ more cubes.
- What other ways can you determine the volume of a rectangular prism?
 - We can also use the formula $V = l \cdot w \cdot h$.

MP.1

Example 1 (5 minutes)

Example 1

A box with the same dimensions as the prism in the Opening Exercise will be used to ship miniature dice whose side lengths have been cut in half. The dice are $\frac{1}{2}$ in. \times $\frac{1}{2}$ in. \times $\frac{1}{2}$ in. cubes. How many dice of this size can fit in the box?

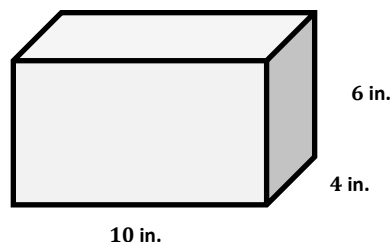

Scaffolding:

Students may need a considerable amount of time to make sense of cubes with fractional side lengths. An additional exercise has been included at the end of this lesson to use when needed.

- How many cubes could we fit across the length? The width? The height?
 - *Two cubes would fit across a 1-inch length. So I would need to double the lengths to get the number of cubes. Twenty cubes will fit across the 10-inch length, eight cubes will fit across the 4-inch width, and twelve cubes will fit across the 6-inch height.*
- How can you use this information to determine the number of $\frac{1}{2}$ in. \times $\frac{1}{2}$ in. \times $\frac{1}{2}$ in. cubes it will take to fill the box?
 - *I can multiply the number of cubes in the length, width, and height.*
 - $20 \times 8 \times 12 = 1,920$ of the smaller cubes.
- How many of these smaller cubes will fit into the 1 in. \times 1 in. \times 1 in. cube?
 - *Two will fit across the length, two across the width, and two for the height. $2 \times 2 \times 2 = 8$. Eight smaller cubes will fit in the larger cube.*
- How does the number of cubes in this example compare to the number of cubes that would be needed in the Opening Exercise?
 - $\frac{\text{new}}{\text{old}} = \frac{1,920}{240} = 8$
 - *If I fill the same box with cubes that are half the length, I will need 8 times as many.*
- How is the volume of the box related to the number of cubes that will fit in it?
 - *The volume of the box is $\frac{1}{8}$ of the number of cubes that will fit in it.*
- What is the volume of 1 cube?
 - $V = \frac{1}{2} \text{ in.} \times \frac{1}{2} \text{ in.} \times \frac{1}{2} \text{ in.}$
 - $V = \frac{1}{8} \text{ in}^3$
- What is the product of the number of cubes and the volume of the cubes? What does this product represent?
 - $1,920 \times \frac{1}{8} = 240$

Example 2 (5 minutes)

Example 2

A $\frac{1}{4}$ in. cube is used to fill the prism.

How many $\frac{1}{4}$ in. cubes will it take to fill the prism?

What is the volume of the prism?

How is the number of cubes related to the volume?

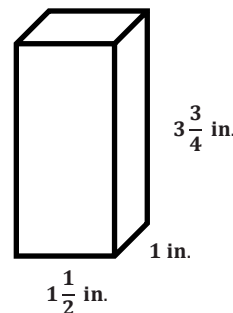

- How would you determine, or find, the number of cubes that fills the prism?
 - *One method would be to determine the number of cubes that will fit across the length, width, and height. Then I would multiply.*
 6 will fit across the length, 4 across the width, and 15 across the height.
 $6 \times 4 \times 15 = 360$ cubes
- How are the number of cubes and the volume related?
 - *The volume is equal to the number of cubes times the volume of one cube.*
 The volume of one cube is $\frac{1}{4}$ in. \times $\frac{1}{4}$ in. \times $\frac{1}{4}$ in. = $\frac{1}{64}$ in³.
 360 cubes \times $\frac{1}{64}$ in³ = $\frac{360}{64}$ in³ = $5\frac{40}{64}$ in³ = $5\frac{5}{8}$ in³
- What other method can be used to determine the volume?
 - $V = lwh$
 - $V = \left(1\frac{1}{2}$ in.) $(1$ in.) $\left(3\frac{3}{4}$ in.)
 - $V = \frac{3}{2}$ in. \times $\frac{1}{1}$ in. \times $\frac{15}{4}$ in.
 - $V = \frac{45}{8}$ in³ = $5\frac{5}{8}$ in³
- Would any other size cubes fit perfectly inside the prism with no space left over?
 - *We would not be able to use cubes with side lengths of $\frac{1}{2}$ in., $\frac{1}{3}$ in., or $\frac{2}{3}$ in. because there would be left over spaces. However, we could use a cube with a side length of $\frac{1}{8}$ in.*

Exercises 1–5 (20 minutes)

Students will work in pairs.

Exercises 1–5

1. Use the prism to answer the following questions.

a. Calculate the volume.

$V = lwh$

$V = \left(5\frac{1}{3}$ cm) $\left(\frac{2}{3}$ cm) $\left(1\frac{1}{3}$ cm)

$V = \frac{16}{3}$ cm \times $\frac{2}{3}$ cm \times $\frac{4}{3}$ cm

$V = \frac{128}{27}$ cm³

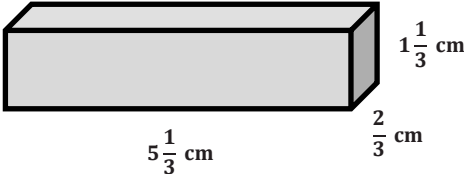

b. If you have to fill the prism with cubes whose side lengths are less than 1 cm, what size would be best?

The best choice would be a cube with side lengths of $\frac{1}{3}$ cm.

- c. How many of the cubes would fit in the prism?

$$16 \times 2 \times 4 = 128 \text{ cubes}$$

- d. Use the relationship between the number of cubes and the volume to prove that your volume calculation is correct.

$$\text{The volume of one cube would be } \frac{1}{3} \text{ cm} \times \frac{1}{3} \text{ cm} \times \frac{1}{3} \text{ cm} = \frac{1}{27} \text{ cm}^3.$$

$$\text{Since there are 128 cubes, the volume would be } 128 \times \frac{1}{27} \text{ cm}^3 = \frac{128}{27} \text{ cm}^3.$$

2. Calculate the volume of the following rectangular prisms.

a.

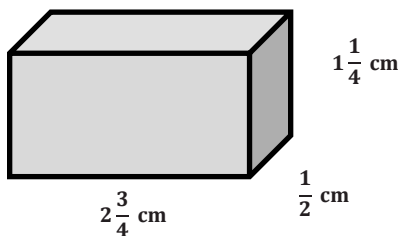

$$V = lwh$$

$$V = \left(2\frac{3}{4} \text{ cm}\right) \left(\frac{1}{2} \text{ cm}\right) \left(1\frac{1}{4} \text{ cm}\right)$$

$$V = \frac{11}{4} \text{ cm} \times \frac{1}{2} \text{ cm} \times \frac{5}{4} \text{ cm}$$

$$V = \frac{55}{32} \text{ cm}^3$$

b.

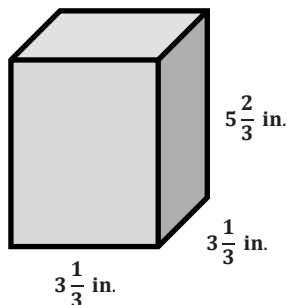

$$V = lwh$$

$$V = \left(3\frac{1}{3} \text{ in.}\right) \left(3\frac{1}{3} \text{ in.}\right) \left(5\frac{2}{3} \text{ in.}\right)$$

$$V = \frac{10}{3} \text{ in.} \times \frac{10}{3} \text{ in.} \times \frac{17}{3} \text{ in.}$$

$$V = \frac{1,700}{27} \text{ in}^3$$

3. A toy company is packaging its toys to be shipped. Some of the very small toys are placed inside a cube shaped box with side lengths of $\frac{1}{2}$ in. These smaller boxes are then packed into a shipping box with dimensions of $12 \text{ in.} \times 4\frac{1}{2} \text{ in.} \times 3\frac{1}{2} \text{ in.}$

- a. How many small toys can be packed into the larger box for shipping?

$$24 \times 9 \times 7 = 1,512 \text{ toys}$$

- b. Use the number of toys that can be shipped in the box to help determine the volume of the box.

$$\text{One small box would have a volume of } \frac{1}{2} \text{ in.} \times \frac{1}{2} \text{ in.} \times \frac{1}{2} \text{ in.} = \frac{1}{8} \text{ in}^3.$$

$$\text{Now I will multiply the number of cubes by the volume of the cube. } 1512 \times \frac{1}{8} \text{ in}^3 = \frac{1,512}{8} \text{ in}^3 = 189 \text{ in}^3.$$

4. A rectangular prism with a volume of 8 cubic units is filled with cubes. First it is filled with cubes with side lengths of $\frac{1}{2}$ unit. Then it is filled with cubes with side lengths of $\frac{1}{3}$ unit.

- a. How many more of the cubes with $\frac{1}{3}$ unit side lengths than cubes with $\frac{1}{2}$ unit side lengths will be needed to fill the prism?

There are 8 cubes with $\frac{1}{2}$ unit side lengths in 1 cubic unit. Since we have 8 cubic units, we would have $8 \times 8 = 64$ total cubes with $\frac{1}{2}$ unit side lengths.

There are 27 cubes with $\frac{1}{3}$ unit side lengths in 1 cubic unit. Since we have 8 cubic units, we would have $8 \times 27 = 216$ total cubes with $\frac{1}{3}$ unit side lengths.

$$216 - 64 = 152 \text{ more cubes}$$

- b. Why does it take more cubes with $\frac{1}{3}$ unit side lengths to fill the prism?

$\frac{1}{3} < \frac{1}{2}$. The side length is shorter for the cube with a $\frac{1}{3}$ unit side length, so it takes more to fill the rectangular prism.

5. Calculate the volume of the rectangular prism. Show two different methods for determining the volume.

Method One

$$V = lwh$$

$$V = \left(1\frac{1}{2} m\right) \left(\frac{3}{4} m\right) \left(4\frac{1}{2} m\right)$$

$$V = \left(\frac{3}{2} m\right) \left(\frac{3}{4} m\right) \left(\frac{9}{2} m\right)$$

$$V = \frac{81}{16} m^3$$

$$V = 5\frac{1}{16} m^3$$

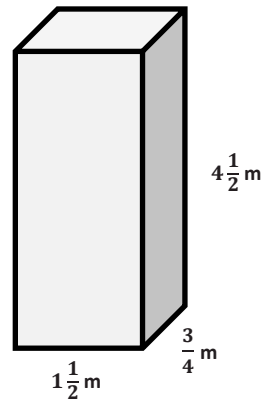

Method Two

Fill the rectangular prism with cubes that are $\frac{1}{4} m \times \frac{1}{4} m \times \frac{1}{4} m$.

The volume of the cubes is $\frac{1}{64} m^3$.

6 cubes across the length, 3 cubes across the width, and 18 cubes across the height.

$$6 \times 3 \times 18 = 324 \text{ cubes total}$$

$$324 \text{ cubes} \times \frac{1}{64} m^3 = 5\frac{1}{16} m^3$$

Closing (2 minutes)

- When you want to find the volume of a rectangular prism that has sides with fractional lengths, what are some methods you can use?

Exit Ticket (5 minutes)

Name _____

Date _____

Lesson 11: Volume with Fractional Edge Lengths and Unit Cubes

Exit Ticket

Calculate the volume of the rectangular prism using two different methods. Label your solutions Method 1 and Method 2.

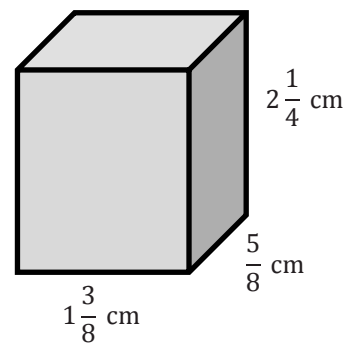

Exit Ticket Sample Solutions

Calculate the volume of the rectangular prism using two different methods. Label your solutions Method 1 and Method 2.

Method 1

$$V = lwh$$

$$V = \left(1\frac{3}{8} \text{ cm}\right) \left(\frac{5}{8} \text{ cm}\right) \left(2\frac{1}{4} \text{ cm}\right)$$

$$V = \frac{11}{8} \text{ cm} \times \frac{5}{8} \text{ cm} \times \frac{9}{4} \text{ cm}$$

$$V = \frac{495}{256} \text{ cm}^3$$

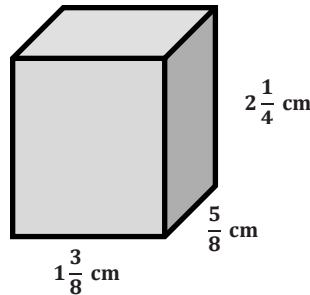

Method 2:

Fill shape with $\frac{1}{8}$ cm cubes.

$$11 \times 5 \times 18 = 990 \text{ cubes}$$

Each cube has a volume of $\frac{1}{8} \text{ cm} \times \frac{1}{8} \text{ cm} \times \frac{1}{8} \text{ cm} = \frac{1}{512} \text{ cm}^3$

$$V = 990 \times \frac{1}{512} \text{ cm}^3 = \frac{990}{512} \text{ cm}^3 = \frac{495}{256} \text{ cm}^3$$

Problem Set Sample Solutions

1. Answer the following questions using this rectangular prism:

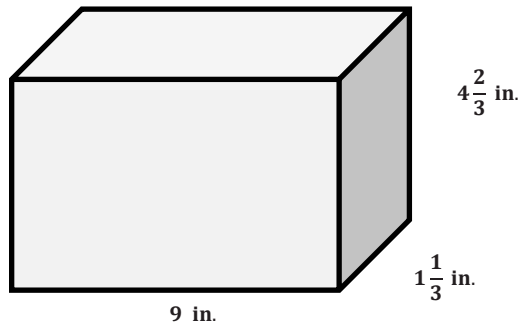

a. What is the volume of the prism?

$$V = lwh$$

$$V = (9 \text{ in.}) \left(1\frac{1}{3} \text{ in.}\right) \left(4\frac{2}{3} \text{ in.}\right)$$

$$V = \left(\frac{9}{1} \text{ in.}\right) \left(\frac{4}{3} \text{ in.}\right) \left(\frac{14}{3} \text{ in.}\right)$$

$$V = \frac{504}{9} \text{ in}^3$$

$$V = 56 \text{ in}^3$$

- b. Linda fills the rectangular prism with cubes that have side lengths of $\frac{1}{3}$ in. How many cubes does she need to fill the rectangular prism?

She would need 27 across by 4 wide and 14 high.

$$\text{Number of cubes} = 27 \times 4 \times 14$$

$$\text{Number of cubes} = 1,512 \text{ cubes with } \frac{1}{3} \text{ in side lengths}$$

- c. How is the number of cubes related to the volume?

$$56 \times 27 = 1,512$$

The number of cubes needed is 27 times larger than the volume.

- d. Why is the number of cubes needed different than the volume?

Because the cubes are not each 1 in., the volume is different than the number of cubes. However, I could multiply the number of cubes by the volume of one cube and still get the original volume.

- e. Should Linda try to fill this rectangular prism with cubes that are $\frac{1}{2}$ in. long on each side? Why or why not?

Because some of the lengths are $\frac{1}{3}$ and some are $\frac{2}{3}$, it would be difficult to use side lengths of $\frac{1}{2}$ to fill the prism.

2. Calculate the volume of the following prisms.

a.

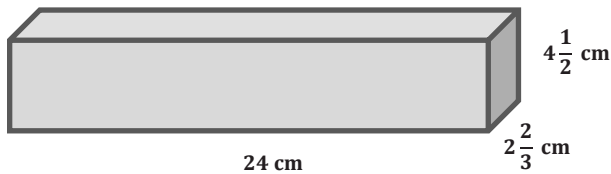

$$V = l w h$$

$$V = (24 \text{ cm}) \left(2\frac{2}{3} \text{ cm}\right) \left(4\frac{1}{2} \text{ cm}\right)$$

$$V = (24 \text{ cm}) \left(\frac{8}{3} \text{ cm}\right) \left(\frac{9}{2} \text{ cm}\right)$$

$$V = \frac{1,728}{6} \text{ cm}^3$$

$$V = 288 \text{ cm}^3$$

b.

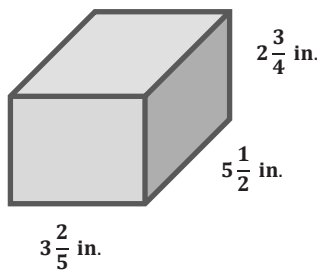

$$V = l w h$$

$$V = \left(3\frac{2}{5} \text{ in.}\right) \left(5\frac{1}{2} \text{ in.}\right) \left(2\frac{3}{4} \text{ in.}\right)$$

$$V = \left(\frac{17}{5} \text{ in.}\right) \left(\frac{11}{2} \text{ in.}\right) \left(\frac{11}{4} \text{ in.}\right)$$

$$V = \frac{2057}{40} \text{ in}^3$$

$$V = 51\frac{17}{40} \text{ in}^3$$

3. A rectangular prism with a volume of 12 cubic units is filled with cubes. First it is filled with cubes with $\frac{1}{2}$ unit side lengths. Then it is filled with cubes with $\frac{1}{3}$ unit side lengths.

- a. How many more of the cubes with $\frac{1}{3}$ unit side lengths than cubes with $\frac{1}{2}$ unit side lengths will be needed to fill the prism?

There are 8 cubes with $\frac{1}{2}$ unit side lengths in 1 cubic unit. Since we have 12 cubic units, we would have $12 \times 8 = 96$ total cubes with $\frac{1}{2}$ unit side lengths.

There are 27 cubes with $\frac{1}{3}$ unit side lengths in 1 cubic unit. Since we have 12 cubic units, we would have $12 \times 27 = 324$ total cubes with $\frac{1}{3}$ unit side lengths.

$$324 - 96 = 228 \text{ more cubes}$$

- b. Finally, the prism is filled with cubes whose side lengths are $\frac{1}{4}$ unit. How many $\frac{1}{4}$ unit cubes would it take to fill the prism?

There are 64 cubes with $\frac{1}{4}$ unit side lengths in 1 cubic unit. Since there are 12 cubic units, we would have $12 \times 64 = 768$ total cubes with side lengths of $\frac{1}{4}$ unit.

4. A toy company is packaging its toys to be shipped. Some of the toys are placed inside a cube shaped box with side lengths of $3\frac{1}{2}$ in. These boxes are then packed into a shipping box with dimensions of 14 in. \times 7 in. \times $3\frac{1}{2}$ in.

- a. How many toys can be packed into the larger box for shipping?

$$4 \times 2 \times 1 = 8 \text{ toys}$$

- b. Use the number of toys that can be shipped in the box to help determine the volume of the box.

$$\text{One small box would have a volume of } 3\frac{1}{2} \text{ in.} \times 3\frac{1}{2} \text{ in.} \times 3\frac{1}{2} \text{ in.} = 42\frac{7}{8} \text{ in}^3$$

$$\text{Now I will multiply the number of cubes by the volume of the cube. } 8 \times 42\frac{7}{8} \text{ in}^3 = 343 \text{ in}^3$$

5. A rectangular prism has a volume of 34.224 cubic meters. The height of the box is 3.1 meters, and the length is 2.4 meters.

- a. Write an equation that relates the volume to the length, width, and height. Let w represent the width, in meters.

$$34.224 = (3.1)(2.4)w$$

- b. Solve the equation.

$$34.224 = 7.44w$$

$$w = 4.6$$

The width is 4.6 m.

Additional Exercise from Scaffolding Box

This is a sample activity that helps foster understanding of a cube with fractional edge length. It begins with three (two-dimensional) squares with side lengths of 1 unit, $\frac{1}{2}$ unit, and $\frac{1}{3}$ unit, which leads to understanding of three-dimensional cubes that have edge lengths of 1 unit, $\frac{1}{2}$ unit, and $\frac{1}{3}$ unit.

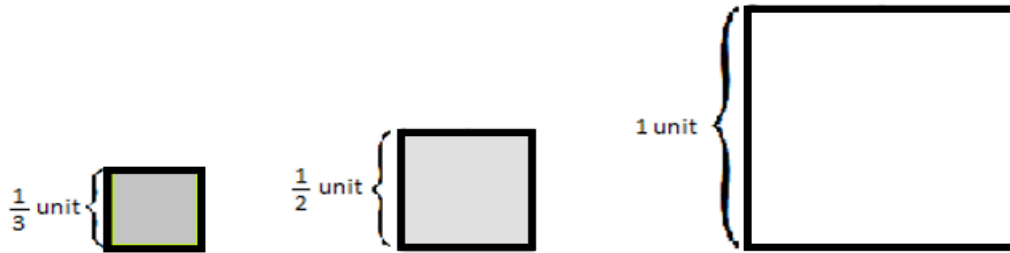

- How many squares with $\frac{1}{2}$ unit side lengths will fit in a square with 1 unit side lengths?

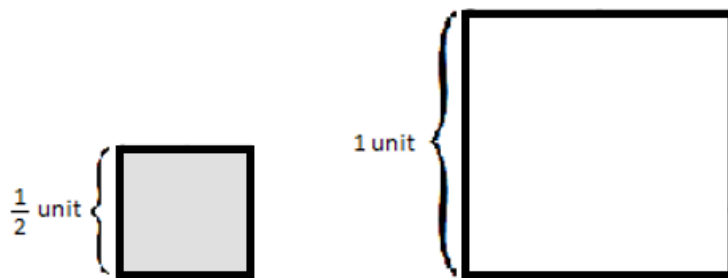

- Four squares with $\frac{1}{2}$ unit side lengths will fit in the square with 1 unit side lengths.

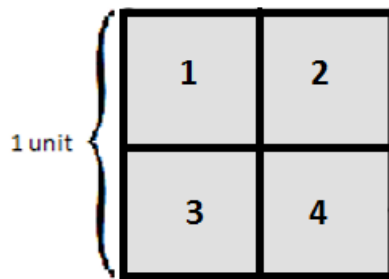

- What does this mean about the area of a square with $\frac{1}{2}$ unit side lengths?
 - The area of a square with $\frac{1}{2}$ unit side lengths is $\frac{1}{4}$ of the area of a square with 1 unit, so it has an area of $\frac{1}{4}$ square units.

- How many squares with side lengths of $\frac{1}{3}$ units will fit in a square with side lengths 1 unit?

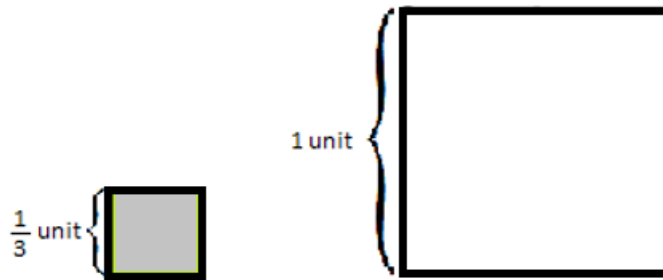

- Nine squares with side lengths of $\frac{1}{3}$ unit will fit in the square with side lengths of 1 unit.

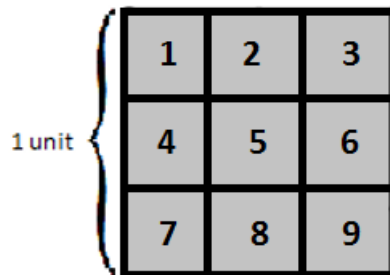

- What does this mean about the area of a square with $\frac{1}{3}$ unit side lengths?
 - The area of a square with $\frac{1}{3}$ unit side lengths is $\frac{1}{9}$ of the area of a square with 1 unit side lengths, so it has an area of $\frac{1}{9}$ square units.
- Let's look at what we've seen so far:

Side Length (units)	How many fit into a unit square?
1	1
$\frac{1}{2}$	4
$\frac{1}{3}$	9

Sample questions to pose:

- Make a prediction about how many squares with $\frac{1}{4}$ unit side lengths will fit into a unit square; then draw a picture to justify your prediction.
 - 16 squares

- How could you determine the number of $\frac{1}{2}$ unit side length squares that would cover a figure with an area of 15 square units? How many $\frac{1}{3}$ unit side length squares would cover the same figure?
 - 4 squares of $\frac{1}{2}$ unit side lengths fit in each 1 square unit. So if there are 15 square units, there will be $15 \times 4 = 60$.
- Now let's see what happens when we consider cubes of 1 unit, $\frac{1}{2}$ unit, and $\frac{1}{3}$ unit side lengths.

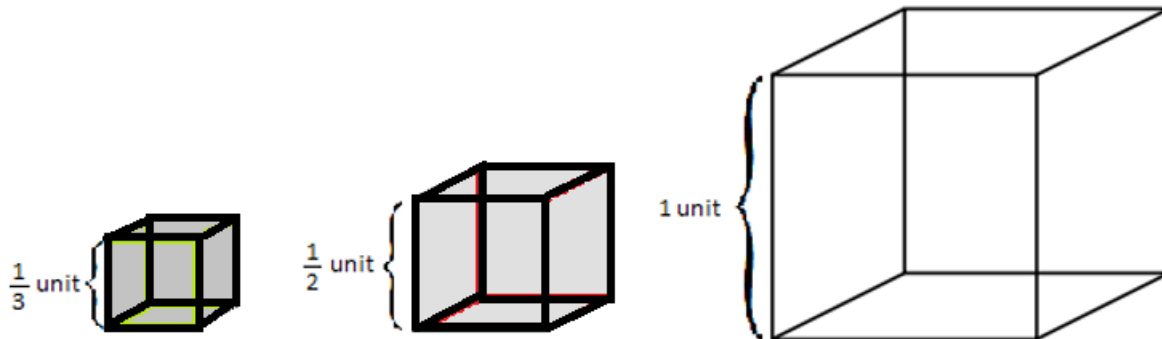

- How many cubes with $\frac{1}{2}$ unit side lengths will fit in a cube with 1 unit side lengths?

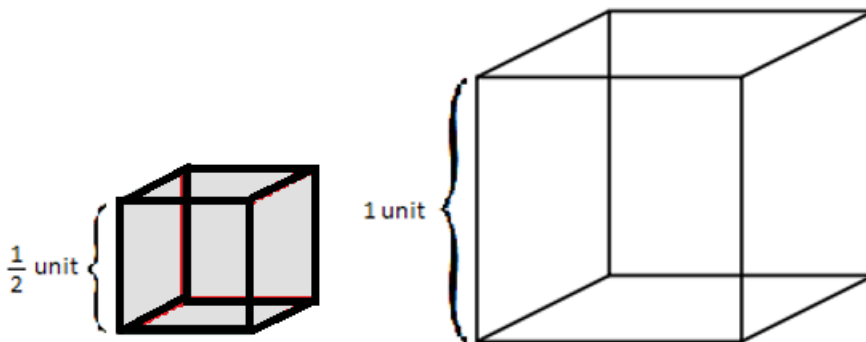

- Eight of the cubes with $\frac{1}{2}$ unit side lengths will fit into the cube with a 1 unit side length.

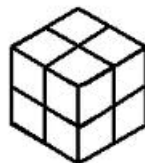

- What does this mean about the volume of a cube with $\frac{1}{2}$ unit side lengths?
 - The volume of a cube with $\frac{1}{2}$ unit side lengths is $\frac{1}{8}$ of the volume of a cube with 1 unit side lengths, so it has a volume of $\frac{1}{8}$ cubic units.

- How many cubes with $\frac{1}{3}$ unit side lengths will fit in a cube with 1 unit side lengths?

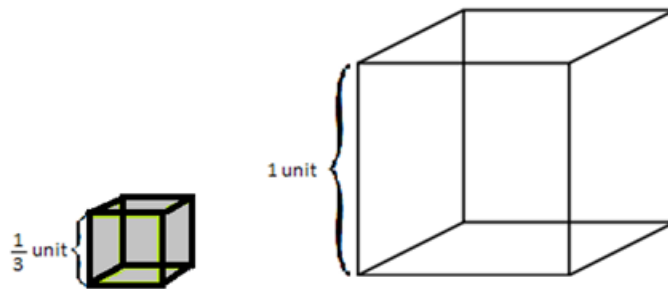

- 27 of the cubes with $\frac{1}{3}$ unit side lengths will fit into the cube with 1 unit side lengths.
- What does this mean about the volume of a cube with $\frac{1}{3}$ unit side lengths?
 - The volume of a cube with $\frac{1}{3}$ unit side lengths is $\frac{1}{27}$ of the volume of a square with 1 unit, so it has a volume of $\frac{1}{27}$ cubic units.

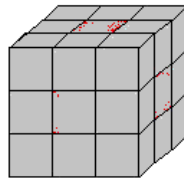

- Let's look at what we've seen so far:

Side Length (units)	How many fit into a unit cube?
1	1
$\frac{1}{2}$	8
$\frac{1}{3}$	27

Sample questions to pose:

- Make a prediction about how many cubes with $\frac{1}{4}$ unit side lengths will fit into a unit cube, and then draw a picture to justify your prediction.
 - 64 cubes
- How could you determine the number of $\frac{1}{2}$ unit side length cubes that would fill a figure with a volume of 15 cubic units? How many $\frac{1}{3}$ unit side length cubes would fill the same figure?
 - 8 cubes of $\frac{1}{2}$ unit fit in each 1 cubic unit. So if there are 15 cubic units, there will be 120 cubes because $15 \times 8 = 120$.

Understanding Volume

Volume

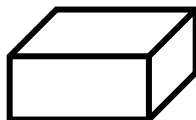

- Volume is the amount of space inside a three-dimensional figure.
- It is measured in cubic units.
- It is the number of cubic units needed to fill the inside of the figure.

Cubic Units

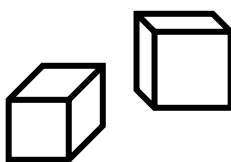

- Cubic units measure the same on all sides. A cubic centimeter is one centimeter on all sides; a cubic inch is one inch on all sides, etc.
- Cubic units can be shortened using the exponent 3.
 $6 \text{ cubic cm} = 6 \text{ cm}^3$
- Different cubic units can be used to measure the volume of space figures – cubic inches, cubic yards, cubic centimeters, etc.



Multiplication of Fractions – Round 1

Number Correct: _____

Directions: *Determine the product of the fractions.*

1.	$\frac{1}{2} \times \frac{5}{8}$	
2.	$\frac{3}{4} \times \frac{3}{5}$	
3.	$\frac{1}{4} \times \frac{7}{8}$	
4.	$\frac{3}{9} \times \frac{2}{5}$	
5.	$\frac{5}{8} \times \frac{3}{7}$	
6.	$\frac{3}{7} \times \frac{4}{9}$	
7.	$\frac{2}{5} \times \frac{3}{8}$	
8.	$\frac{4}{9} \times \frac{5}{9}$	
9.	$\frac{2}{3} \times \frac{5}{7}$	
10.	$\frac{2}{7} \times \frac{3}{10}$	
11.	$\frac{3}{4} \times \frac{9}{10}$	
12.	$\frac{3}{5} \times \frac{2}{9}$	
13.	$\frac{2}{10} \times \frac{5}{6}$	
14.	$\frac{5}{8} \times \frac{7}{10}$	
15.	$\frac{3}{5} \times \frac{7}{9}$	

16.	$\frac{2}{9} \times \frac{3}{8}$	
17.	$\frac{3}{8} \times \frac{8}{9}$	
18.	$\frac{3}{4} \times \frac{7}{9}$	
19.	$\frac{3}{5} \times \frac{10}{13}$	
20.	$1\frac{2}{7} \times \frac{7}{8}$	
21.	$3\frac{1}{2} \times 3\frac{5}{6}$	
22.	$1\frac{7}{8} \times 5\frac{1}{5}$	
23.	$5\frac{4}{5} \times 3\frac{2}{9}$	
24.	$7\frac{2}{5} \times 2\frac{3}{8}$	
25.	$4\frac{2}{3} \times 2\frac{3}{10}$	
26.	$3\frac{3}{5} \times 6\frac{1}{4}$	
27.	$2\frac{7}{9} \times 5\frac{1}{3}$	
28.	$4\frac{3}{8} \times 3\frac{1}{5}$	
29.	$3\frac{1}{3} \times 5\frac{2}{5}$	
30.	$2\frac{2}{3} \times 7$	

Multiplication of Fractions – Round 1 [KEY]

Directions: Determine the product of the fractions.

1.	$\frac{1}{2} \times \frac{5}{8}$	$\frac{5}{16}$
2.	$\frac{3}{4} \times \frac{3}{5}$	$\frac{9}{20}$
3.	$\frac{1}{4} \times \frac{7}{8}$	$\frac{7}{32}$
4.	$\frac{3}{9} \times \frac{2}{5}$	$\frac{6}{45}$
5.	$\frac{5}{8} \times \frac{3}{7}$	$\frac{15}{56}$
6.	$\frac{3}{7} \times \frac{4}{9}$	$\frac{12}{63}$
7.	$\frac{2}{5} \times \frac{3}{8}$	$\frac{6}{40} = \frac{3}{20}$
8.	$\frac{4}{9} \times \frac{5}{9}$	$\frac{20}{81}$
9.	$\frac{2}{3} \times \frac{5}{7}$	$\frac{10}{21}$
10.	$\frac{2}{7} \times \frac{3}{10}$	$\frac{6}{70} = \frac{3}{35}$
11.	$\frac{3}{4} \times \frac{9}{10}$	$\frac{27}{40}$
12.	$\frac{3}{5} \times \frac{2}{9}$	$\frac{6}{45} = \frac{2}{15}$
13.	$\frac{2}{10} \times \frac{5}{6}$	$\frac{10}{60} = \frac{1}{6}$
14.	$\frac{5}{8} \times \frac{7}{10}$	$\frac{35}{80} = \frac{7}{16}$
15.	$\frac{3}{5} \times \frac{7}{9}$	$\frac{21}{45} = \frac{7}{15}$

16.	$\frac{2}{9} \times \frac{3}{8}$	$\frac{6}{72} = \frac{1}{12}$
17.	$\frac{3}{8} \times \frac{8}{9}$	$\frac{24}{72} = \frac{1}{3}$
18.	$\frac{3}{4} \times \frac{7}{9}$	$\frac{21}{36} = \frac{7}{12}$
19.	$\frac{3}{5} \times \frac{10}{13}$	$\frac{30}{65} = \frac{6}{13}$
20.	$1\frac{2}{7} \times \frac{7}{8}$	$\frac{63}{56} = 1\frac{1}{8}$
21.	$3\frac{1}{2} \times 3\frac{5}{6}$	$\frac{161}{12} = 13\frac{5}{12}$
22.	$1\frac{7}{8} \times 5\frac{1}{5}$	$\frac{390}{40} = 9\frac{3}{4}$
23.	$5\frac{4}{5} \times 3\frac{2}{9}$	$\frac{841}{45} = 18\frac{31}{45}$
24.	$7\frac{2}{5} \times 2\frac{3}{8}$	$\frac{703}{40} = 17\frac{23}{40}$
25.	$4\frac{2}{3} \times 2\frac{3}{10}$	$\frac{322}{30} = 10\frac{11}{15}$
26.	$3\frac{3}{5} \times 6\frac{1}{4}$	$\frac{450}{20} = 22\frac{1}{2}$
27.	$2\frac{7}{9} \times 5\frac{1}{3}$	$\frac{400}{27} = 14\frac{22}{27}$
28.	$4\frac{3}{8} \times 3\frac{1}{5}$	$\frac{560}{40} = 14$
29.	$3\frac{1}{3} \times 5\frac{2}{5}$	$\frac{270}{15} = 18$
30.	$2\frac{2}{3} \times 7$	$\frac{56}{3} = 18\frac{2}{3}$



Multiplication of Fractions – Round 2

Number Correct: _____

Improvement: _____

Directions: *Determine the product of the fractions.*

1.	$\frac{2}{3} \times \frac{5}{7}$	
2.	$\frac{1}{4} \times \frac{3}{5}$	
3.	$\frac{2}{3} \times \frac{2}{5}$	
4.	$\frac{5}{9} \times \frac{5}{8}$	
5.	$\frac{5}{8} \times \frac{3}{7}$	
6.	$\frac{3}{4} \times \frac{7}{8}$	
7.	$\frac{2}{5} \times \frac{3}{8}$	
8.	$\frac{3}{4} \times \frac{3}{4}$	
9.	$\frac{7}{8} \times \frac{3}{10}$	
10.	$\frac{4}{9} \times \frac{1}{2}$	
11.	$\frac{6}{11} \times \frac{3}{8}$	
12.	$\frac{5}{6} \times \frac{9}{10}$	
13.	$\frac{3}{4} \times \frac{2}{9}$	
14.	$\frac{4}{11} \times \frac{5}{8}$	
15.	$\frac{2}{3} \times \frac{9}{10}$	

16.	$\frac{3}{11} \times \frac{2}{9}$	
17.	$\frac{3}{5} \times \frac{10}{21}$	
18.	$\frac{4}{9} \times \frac{3}{10}$	
19.	$\frac{3}{8} \times \frac{4}{5}$	
20.	$\frac{6}{11} \times \frac{2}{15}$	
21.	$1\frac{2}{3} \times \frac{3}{5}$	
22.	$2\frac{1}{6} \times \frac{3}{4}$	
23.	$1\frac{2}{5} \times 3\frac{2}{3}$	
24.	$4\frac{2}{3} \times 1\frac{1}{4}$	
25.	$3\frac{1}{2} \times 2\frac{4}{5}$	
26.	$3 \times 5\frac{3}{4}$	
27.	$1\frac{2}{3} \times 3\frac{1}{4}$	
28.	$2\frac{3}{5} \times 3$	
29.	$1\frac{5}{7} \times 3\frac{1}{2}$	
30.	$3\frac{1}{3} \times 1\frac{9}{10}$	

Multiplication of Fractions – Round 2 [KEY]

Directions: Determine the product of the fractions.

1.	$\frac{2}{3} \times \frac{5}{7}$	$\frac{10}{21}$
2.	$\frac{1}{4} \times \frac{3}{5}$	$\frac{3}{20}$
3.	$\frac{2}{3} \times \frac{2}{5}$	$\frac{4}{15}$
4.	$\frac{5}{9} \times \frac{5}{8}$	$\frac{25}{72}$
5.	$\frac{5}{8} \times \frac{3}{7}$	$\frac{15}{56}$
6.	$\frac{3}{4} \times \frac{7}{8}$	$\frac{21}{32}$
7.	$\frac{2}{5} \times \frac{3}{8}$	$\frac{6}{40} = \frac{3}{20}$
8.	$\frac{3}{4} \times \frac{3}{4}$	$\frac{9}{16}$
9.	$\frac{7}{8} \times \frac{3}{10}$	$\frac{21}{80}$
10.	$\frac{4}{9} \times \frac{1}{2}$	$\frac{4}{18} = \frac{2}{9}$
11.	$\frac{6}{11} \times \frac{3}{8}$	$\frac{18}{88} = \frac{9}{44}$
12.	$\frac{5}{6} \times \frac{9}{10}$	$\frac{45}{60} = \frac{3}{4}$
13.	$\frac{3}{4} \times \frac{2}{9}$	$\frac{6}{36} = \frac{1}{6}$
14.	$\frac{4}{11} \times \frac{5}{8}$	$\frac{20}{88} = \frac{5}{22}$
15.	$\frac{2}{3} \times \frac{9}{10}$	$\frac{18}{30} = \frac{3}{5}$

16.	$\frac{3}{11} \times \frac{2}{9}$	$\frac{6}{99} = \frac{2}{33}$
17.	$\frac{3}{5} \times \frac{10}{21}$	$\frac{30}{105} = \frac{2}{7}$
18.	$\frac{4}{9} \times \frac{3}{10}$	$\frac{12}{90} = \frac{2}{15}$
19.	$\frac{3}{8} \times \frac{4}{5}$	$\frac{12}{40} = \frac{3}{10}$
20.	$\frac{6}{11} \times \frac{2}{15}$	$\frac{12}{165} = \frac{4}{55}$
21.	$1\frac{2}{3} \times \frac{3}{5}$	$\frac{15}{15} = 1$
22.	$2\frac{1}{6} \times \frac{3}{4}$	$\frac{39}{24} = 1\frac{15}{24} = 1\frac{5}{8}$
23.	$1\frac{2}{5} \times 3\frac{2}{3}$	$\frac{77}{15} = 5\frac{2}{15}$
24.	$4\frac{2}{3} \times 1\frac{1}{4}$	$\frac{70}{12} = 5\frac{10}{12} = 5\frac{5}{6}$
25.	$3\frac{1}{2} \times 2\frac{4}{5}$	$\frac{98}{10} = 9\frac{8}{10} = 9\frac{4}{5}$
26.	$3 \times 5\frac{3}{4}$	$\frac{69}{4} = 17\frac{1}{4}$
27.	$1\frac{2}{3} \times 3\frac{1}{4}$	$\frac{65}{12} = 5\frac{5}{12}$
28.	$2\frac{3}{5} \times 3$	$\frac{69}{5} = 13\frac{4}{5}$
29.	$1\frac{5}{7} \times 3\frac{1}{2}$	$\frac{84}{14} = 6$
30.	$3\frac{1}{3} \times 1\frac{9}{10}$	$\frac{190}{30} = 6\frac{10}{30} = 6\frac{1}{3}$