

Lesson 1: Generating Equivalent Expressions

Classwork

Opening Exercise

Each envelope contains a number of triangles and a number of quadrilaterals. For this exercise, let t represent the number of triangles, and let q represent the number of quadrilaterals.

- Write an expression, using t and q , that represents the total number of sides in your envelope. Explain what the terms in your expression represent.
- You and your partner have the same number of triangles and quadrilaterals in your envelopes. Write an expression that represents the total number of sides that you and your partner have. If possible, write more than one expression to represent this total.
- Each envelope in the class contains the same number of triangles and quadrilaterals. Write an expression that represents the total number of sides in the room.
- Use the given values of t and q , and your expression from part (a), to determine the number of sides that should be found in your envelope.

- e. Use the same values for t and q , and your expression from part (b), to determine the number of sides that should be contained in your envelope and your partner's envelope combined.
- f. Use the same values for t and q , and your expression from part (c), to determine the number of sides that should be contained in all of the envelopes combined.
- g. What do you notice about the various expressions in parts (e) and (f)?

Example 1: Any Order, Any Grouping Property with Addition

- a. Rewrite $5x + 3x$ and $5x - 3x$ by combining like terms.

Write the original expressions and expand each term using addition. What are the new expressions equivalent to?

- b. Find the sum of $2x + 1$ and $5x$.

- c. Find the sum of $-3a + 2$ and $5a - 3$.

Example 2: Any Order, Any Grouping with Multiplication

Find the product of $2x$ and 3.

Example 3: Any Order, Any Grouping in Expressions with Addition and Multiplication

a. $3(2x)$

b. $4y(5)$

c. $4 \cdot 2 \cdot z$

d. $3(2x) + 4y(5)$

e. $3(2x) + 4y(5) + 4 \cdot 2 \cdot z$

f. Alexander says that $3x + 4y$ is equivalent to $(3)(4) + xy$ because of any order, any grouping. Is he correct? Why or why not?

Relevant Vocabulary

Variable (description): A *variable* is a symbol (such as a letter) that represents a number, i.e., it is a placeholder for a number.

Numerical Expression (description): A *numerical expression* is a number, or it is any combination of sums, differences, products, or divisions of numbers that evaluates to a number.

Value of a Numerical Expression: The *value of a numerical expression* is the number found by evaluating the expression.

Expression (description): An *expression* is a numerical expression, or it is the result of replacing some (or all) of the numbers in a numerical expression with variables.

Equivalent Expressions: Two expressions are *equivalent* if both expressions evaluate to the same number for every substitution of numbers into all the letters in both expressions.

An Expression in Expanded Form: An expression that is written as sums (and/or differences) of products whose factors are numbers, variables, or variables raised to whole number powers is said to be in *expanded form*. A single number, variable, or a single product of numbers and/or variables is also considered to be in expanded form. Examples of expressions in expanded form include: 324 , $3x$, $5x + 3 - 40$, $x + 2x + 3x$, etc.

Term (description): Each summand of an expression in expanded form is called a *term*. For example, the expression $2x + 3x + 5$ consists of 3 terms: $2x$, $3x$, and 5 .

Coefficient of the Term (description): The number found by multiplying just the numbers in a term together. For example, given the product $2 \cdot x \cdot 4$, its equivalent term is $8x$. The number 8 is called the coefficient of the term $8x$.

An Expression in Standard Form: An expression in expanded form with all its like terms collected is said to be in *standard form*. For example, $2x + 3x + 5$ is an expression written in expanded form; however, to be written in standard form, the like terms $2x$ and $3x$ must be combined. The equivalent expression $5x + 5$ is written in standard form.

Lesson Summary

Terms that contain exactly the same variable symbol can be combined by addition or subtraction because the variable represents the same number. Any order, any grouping can be used where terms are added (or subtracted) in order to group together like terms. Changing the orders of the terms in a sum does not affect the value of the expression for given values of the variable(s).

Problem Set

For problems 1–9, write equivalent expressions by combining like terms. Verify the equivalence of your expression and the given expression by evaluating each for the given values: $a = 2$, $b = 5$, and $c = -3$.

- | | | |
|----------------------|----------------------|-----------------------|
| 1. $3a + 5a$ | 2. $8b - 4b$ | 3. $5c + 4c + c$ |
| 4. $3a + 6 + 5$ | 5. $8b + 8 - 4b$ | 6. $5c - 4c + c$ |
| 7. $3a + 6 + 5a - 2$ | 8. $8b + 8 - 4b - 3$ | 9. $5c - 4c + c - 3c$ |

Use any order, any grouping to write equivalent expressions by combining like terms. Then verify the equivalence of your expression to the given expression by evaluating for the value(s) given in each problem.

- $3(6a)$; for $a = 3$
- $5d(4)$; for $d = -2$
- $(5r)(-2)$; for $r = -3$
- $3b(8) + (-2)(7c)$; for $b = 2, c = 3$
- $-4(3s) + 2(-t)$; for $s = \frac{1}{2}, t = -3$
- $9(4p) - 2(3q) + p$; for $p = -1, q = 4$
- $7(4g) + 3(5h) + 2(-3g)$; $g = \frac{1}{2}, h = \frac{1}{3}$

The problems below are follow-up questions to Example 1b from Classwork: Find the sum of $2x + 1$ and $5x$.

- Jack got the expression $7x + 1$, then wrote his answer as $1 + 7x$. Is his answer an equivalent expression? How do you know?
- Jill also got the expression $7x + 1$, then wrote her answer as $1x + 7$. Is her expression an equivalent expression? How do you know?

Lesson 2: Generating Equivalent Expressions

Classwork

Opening Exercise

Additive inverses have a sum of zero. Multiplicative inverses have a product of 1. Fill in the center column of the table with the opposite of the given number or expression, then show the proof that they are opposites. The first row is completed for you.

Expression	Opposite?	Proof of Opposites
1	-1	$1 + (-1) = 0$
3		
-7		
$-\frac{1}{2}$		
x		
$3x$		
$x + 3$		
$3x - 7$		

Example 1: Subtracting Expressions

a. Subtract: $(40 + 9) - (30 + 2)$.

b. Subtract: $(3x + 5y - 4) - (4x + 11)$.

Example 2: Combining Expressions Vertically

a. Find the sum by aligning the expressions vertically.

$$(5a + 3b - 6c) + (2a - 4b + 13c)$$

b. Find the difference by aligning the expressions vertically.

$$(2x + 3y - 4) - (5x + 2)$$

Example 3: Using Expressions to Solve Problems

A stick is x meters long. A string is 4 times as long as the stick.

- a. Express the length of the string in terms of x .

- b. If the total length of the string and the stick is 15 meters long, how long is the string?

Example 4: Expressions from Word Problems

It costs Margo a processing fee of \$3 to rent a storage unit, plus \$17 per month to keep her belongings in the unit. Her friend Carissa wants to store a box of her belongings in Margo's storage unit and tells her that she will pay her \$1 toward the processing fee and \$3 for every month that she keeps the box in storage. Write an expression in standard form that represents how much Margo will have to pay for the storage unit if Carissa contributes. Then, determine how much Margo will pay if she uses the storage unit for 6 months.

Example 5: Extending Use of the Inverse to Division

Find the multiplicative inverses of the terms in the first column. Show that the given number and its multiplicative inverse have a product of 1. Then, use the inverse to write each corresponding expression in standard form. The first row is completed for you.

Given	Multiplicative Inverse?	Proof – Show that their product is 1.	Use each inverse to write its corresponding expression below in standard form.
3	$\frac{1}{3}$	$3 \cdot \frac{1}{3}$ $3 \cdot \frac{1}{3}$ $\frac{1}{3} \cdot \frac{3}{3}$ $\frac{3}{3} = 1$	$12 \div 3$ $12 \cdot \frac{1}{3}$ 4
5			
-2			
$-\frac{3}{5}$			
x			
$2x$			

Relevant Vocabulary

An Expression in Expanded Form: An expression that is written as sums (and/or differences) of products whose factors are numbers, variables, or variables raised to whole number powers is said to be in *expanded form*. A single number, variable, or a single product of numbers and/or variables is also considered to be in expanded form. Examples of expressions in expanded form include: 324 , $3x$, $5x + 3 - 40$, $x + 2x + 3x$, etc.

Term: Each summand of an expression in expanded form is called a *term*. For example, the expression $2x + 3x + 5$ consists of 3 terms: $2x$, $3x$, and 5 .

Coefficient of the Term: The number found by multiplying just the numbers in a term together. For example, given the product $2 \cdot x \cdot 4$, its equivalent term is $8x$. The number 8 is called the coefficient of the term $8x$.

An Expression in Standard Form: An expression in expanded form with all its like terms collected is said to be in *standard form*. For example, $2x + 3x + 5$ is an expression written in expanded form; however, to be written in standard form, the like-terms $2x$ and $3x$ must be combined. The equivalent expression $5x + 5$ is written in standard form.

Lesson Summary

- Rewrite subtraction as adding the opposite before using any order, any grouping.
- Rewrite division as multiplying by the reciprocal before using any order, any grouping.
- The opposite of a sum is the sum of its opposites.
- Division is equivalent to multiplying by the reciprocal.

Problem Set

1. Write each expression in standard form. Verify that your expression is equivalent to the one given by evaluating each expression using $x = 5$.

a. $3x + (2 - 4x)$	b. $3x + (-2 + 4x)$	c. $-3x + (2 + 4x)$
d. $3x + (-2 - 4x)$	e. $3x - (2 + 4x)$	f. $3x - (-2 + 4x)$
g. $3x - (-2 - 4x)$	h. $3x - (2 - 4x)$	i. $-3x - (-2 - 4x)$

- j. In problems (a)–(d) above, what effect does addition have on the terms in parentheses when you removed the parentheses?
- k. In problems (e)–(i), what effect does subtraction have on the terms in parentheses when you removed the parentheses?
2. Write each expression in standard form. Verify that your expression is equivalent to the one given by evaluating each expression for the given value of the variable.

a. $4y - (3 + y); y = 2$	b. $(2b + 1) - b; b = -4$	c. $(6c - 4) - (c - 3); c = -7$
d. $(d + 3d) - (-d + 2); d = 3$	e. $(-5x - 4) - (-2 - 5x); x = 3$	f. $11f - (-2f + 2); f = \frac{1}{2}$
g. $-5g + (6g - 4); g = -2$	h. $(8h - 1) - (h + 3); h = -3$	i. $(7 + w) - (w + 7); w = -4$
j. $(2g + 9h - 5) - (6g - 4h + 2); g = -2$ and $h = 5$		

3. Write each expression in standard form. Verify that your expression is equivalent to the one given by evaluating both expressions for the given value of the variable.

a. $-3(8x); x = \frac{1}{4}$	b. $5 \cdot k \cdot (-7); k = \frac{3}{5}$	c. $2(-6x) \cdot 2; x = \frac{3}{4}$
d. $-3(8x) + 6(4x); x = 2$	e. $8(5m) + 2(3m); m = -2$	f. $-6(2v) + 3a(3); v = \frac{1}{3}; a = \frac{2}{3}$

4. Write each expression in standard form. Verify that your expression is equivalent to the one given by evaluating both expressions for the given value of the variable.

a. $8x \div 2; x = -\frac{1}{4}$	b. $18w \div 6; w = 6$	c. $25r \div 5r; r = -2$
d. $33y \div 11y; y = -2$	e. $56k \div 2k; k = 3$	f. $24xy \div 6y; x = -2; y = 3$

5. Write each word problem in standard form as an expression.
- Find the sum of $-3x$ and $8x$.
 - Find the sum of $-7g$ and $4g + 2$.
 - Find the difference when $6h$ is subtracted from $2h - 4$.
 - Find the difference when $-3n - 7$ is subtracted from $n + 4$.
 - Find the result when $13v + 2$ is subtracted from $11 + 5v$.
 - Find the result when $-18m - 4$ is added to $4m - 14$.
 - What is the result when $-2x + 9$ is taken away from $-7x + 2$?
6. Marty and Stewart are stuffing envelopes with index cards. They are putting x index cards in each envelope. When they are finished, Marty has 15 envelopes and 4 extra index cards, and Stewart has 12 envelopes and 6 extra index cards. Write an expression in standard form that represents the number of index cards the boys started with. Explain what your expression means.
7. The area of the pictured rectangle below is $24b \text{ ft}^2$. Its width is $2b \text{ ft}$. Find the height of the rectangle and name any properties used with the appropriate step.

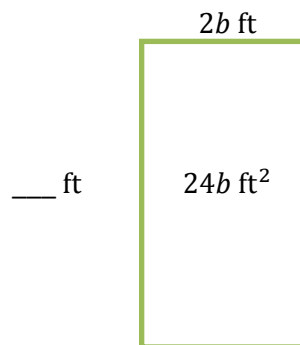

Lesson 3: Writing Products as Sums and Sums as Products

Classwork

Opening Exercise

Solve the problem using a tape diagram. A sum of money was shared between George and Brian in a ratio of 3: 4. If the sum of money was \$56.00, how much did George get?

Example 1

- Represent $3 + 2$ using squares for units.
- Represent $x + 2$ using the same size square for a unit as above.
- Draw a rectangular array for $3(3 + 2)$.
- Draw an array for $3(x+2)$

Key Terms

Distributive Property: The distributive property can be written as the identity:

$$a(b + c) = ab + ac \text{ for all numbers } a, b, \text{ and } c.$$

Exercise 1

Fill in the blanks.

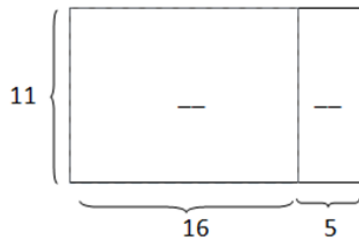

Example 3

Find an equivalent expression by modeling with a rectangular array and applying the distributive property $5(8x + 3)$.

Exercise 2

For parts (a) and (b), draw a model for each expression and apply the distributive property to expand each expression. Substitute the given numerical values to demonstrate equivalency.

a. $2(x + 1), x = 5$

b. $10(2c + 5), c = 1$

For parts (c) and (d), apply the distributive property. Substitute the given numerical values to demonstrate equivalency.

c. $3(4f - 1), f = 2$

d. $9(-3r - 11), r = 10$

Example 4

Rewrite the expression, $(6x + 15) \div 3$, as a sum using the distributive property.

Rewrite $\div 3$ as $\times \frac{1}{3}$ $(6x + 15) \times \frac{1}{3}$

Distribute $(6x) \frac{1}{3} + (15) \frac{1}{3}$

Multiply $2x + 5$

Exercise 3

Rewrite the expressions as a sum.

e. $(2b + 12) \div 2$

f. $(20r - 8) \div 4$

g. $(49g - 7) \div 7$

Example 5

Expand the expression $4(x + y + z)$.

Exercise 4

Expand the expression from a product to a sum so as to remove grouping symbols using an area model and the repeated use of distributive property: $3(x + 2y + 5z)$.

Example 6

A square fountain area with side length s is bordered by a single row of square tiles as shown. Express the total number of tiles needed in terms of s three different ways.

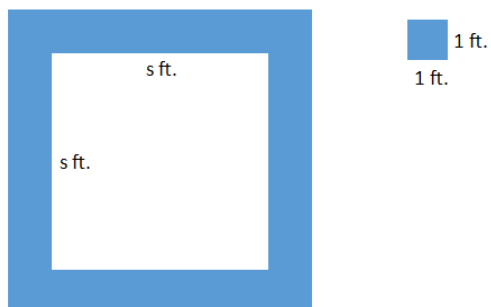

Problem Set

- 1.
- a. Write two equivalent expressions that represent the rectangular array below.



- b. Verify informally that the two equations are equivalent using substitution.
2. You and your friend made up a basketball shooting game. Every shot made from the free throw line is worth 3 points, and every shot made from the half-court mark is worth 6 points. Write an equation that represents the total amount of points, P , if f represents the number of shots made from the free throw line, and h represents the number of shots made from half-court. Explain the equation in words.
3. Use a rectangular array to write the products as sums.
- a. $2(x + 10)$
- b. $3(4b + 12c + 11)$
4. Use the distributive property to write the products as sums.
- a. $3(2x - 1)$
- b. $10(b + 4c)$
- c. $9(g - 5h)$
- d. $7(4n - 5m - 2)$
- e. $a(b + c + 1)$
- f. $(8j - 3l + 9)6$
- g. $(40s + 100t) \div 10$
- h. $(48p + 24) \div 6$
- i. $(2b + 12) \div 2$
- j. $(20r - 8) \div 4$
- k. $(49g - 7) \div 7$
- l. $(14g + 22h) \div \frac{1}{2}$
5. Write the expression in standard form by expanding and collecting like terms.
- a. $4(8m - 7n) + 6(3n - 4m)$
- b. $9(r - s) + 5(2r - 2s)$
- c. $12(1 - 3g) + 8(g + f)$

Example 3

For each expression, write each sum as a product of two factors. Emphasize the importance of the distributive property. Use various equivalent expressions to justify equivalency.

a. $2 \cdot 3 + 5 \cdot 3$

b. $(2 + 5) + (2 + 5) + (2 + 5)$

c. $2 \cdot 2 + (5 + 2) + (5 \cdot 2)$

d. $x \cdot 3 + 5 \cdot 3$

e. $(x + 5) + (x + 5) + (x + 5)$

f. $2x + (5 + x) + 5 \cdot 2$

g. $x \cdot 3 + y \cdot 3$

h. $(x + y) + (x + y) + (x + y)$

i. $2x + (y + x) + 2y$

Example 4

A new miniature golf and arcade opened up in town. For convenient ordering, a play package is available to purchase. It includes two rounds of golf and 20 arcade tokens, plus three dollars off. There is a group of six friends purchasing this package. Let g represent the cost of a round of golf and let t represent the cost of a token. Write two different expressions that represent the total amount this group spent. Explain how each expression describes the situation in a different way.

Exercise 5

- a. What is the opposite of $(-6v + 1)$?
- b. Using the distributive property, write an equivalent expression for part (a).

Example 6

Rewrite $5a - (a - 3b)$ in standard form. Justify each step applying the rules for subtracting and the distributive property.

Exercise 6

Expand each expression and collect like terms.

a. $-3(2p - 3q)$

b. $-a - (a - b)$

Problem Set

1. Write each expression as the product of two factors.

- a. $1 \cdot 3 + 7 \cdot 3$
- b. $(1 + 7) + (1 + 7) + (1 + 7)$
- c. $2 \cdot 1 + (1 + 7) + (7 \cdot 2)$
- d. $h \cdot 3 + 6 \cdot 3$
- e. $(h + 6) + (h + 6) + (h + 6)$
- f. $2h + (6 + h) + 6 \cdot 2$
- g. $j \cdot 3 + k \cdot 3$
- h. $(j + k) + (j + k) + (j + k)$
- i. $2j + (k + j) + 2k$

2. Write each sum as a product of two factors.

- a. $6 \cdot 7 + 3 \cdot 7$
- b. $(8 + 9) + (8 + 9) + (8 + 9)$
- c. $4 + (12 + 4) + (5 \cdot 4)$
- d. $2y \cdot 3 + 4 \cdot 3$
- e. $(x + 5) + (x + 5)$
- f. $3x + (2 + x) + 5 \cdot 2$
- g. $f \cdot 6 + g \cdot 6$
- h. $(c + d) + (c + d) + (c + d) + (c + d)$
- i. $2r + r + s + 2s$

3. Use the following rectangular array to answer the questions below.

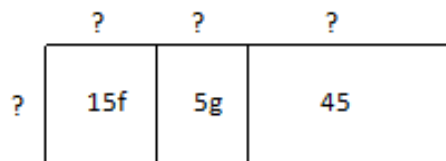

- a. Fill in the missing information.
 - b. Write the sum represented in the rectangular array.
 - c. Use the missing information from part (a) to write the sum from part (b) as a product of two factors.
4. Write the sum as a product of two factors.
- a. $81w + 48$
 - b. $10 - 25t$
 - c. $12a + 16b + 8$
5. Xander goes to the movies with his family. Each family member buys a ticket and two boxes of popcorn. If there are five members of his family, let t represent the cost of a ticket and p represent the cost of a box of popcorn. Write two different expressions that represent the total amount his family spent. Explain how each expression describes the situation in a different way.

6. Write each expression in standard form.

a. $-3(1 - 8m - 2n)$

b. $5 - 7(-4q + 5)$

c. $-(2h - 9) - 4h$

d. $6(-5r - 4) - 2(r - 7s - 3)$

7. Combine like terms to write each expression in standard form.

a. $(r - s) + (s - r)$

b. $(-r + s) + (s - r)$

c. $(-r - s) - (-s - r)$

d. $(r - s) + (s - t) + (t - r)$

e. $(r - s) - (s - t) - (t - r)$

Lesson 5: Using the Identity and Inverse to Write Equivalent Expressions

Classwork

Opening Exercise

- In the morning, Harrison checked the temperature outside to find that it was -12°F . Later in the afternoon, the temperature rose 12°F . Write an expression representing the temperature change. What was the afternoon temperature?
- Rewrite subtraction as adding the inverse for the following problems, and find the sum.
 - $2 - 2$
 - $-4 - (-4)$
 - The difference of 5 and 5.
 - $g - g$

3. What pattern can you deduce from Opening Exercises 1 and 2?
4. Add or subtract.
- $16 + 0$
 - $0 - 7$
 - $-4 + 0$
 - $0 + d$
 - What pattern do you notice in (a)–(d)?
5. Your younger sibling runs up to you and excitedly exclaims, “I’m thinking of a number. If I add it to the number 2 ten times, that is, $2 + \text{my number} + \text{my number} + \text{my number} \dots$ and so on, then the answer is 2. What is my number?” You almost immediately answer, “zero,” but are you sure? Can you find a different number (other than zero) that has the same property? If not, can you justify that your answer is the only correct answer?

Example 1

Write the sum and then write an equivalent expression by collecting like terms and removing parentheses.

- $2x$ and $-2x + 3$

- $2x - 7$ and the opposite of $2x$

- The opposite of $(5x - 1)$ and $5x$

Exercise 1

With a partner, take turns alternating roles as writer and speaker. The speaker verbalizes how to rewrite the sum and properties that justify each step as the writer writes what is being spoken without any input. At the end of each problem, discuss in pairs the resulting equivalent expressions.

Write the sum and then write an equivalent expression by collecting like terms and removing parentheses whenever possible.

- -4 and $4b + 4$

- $3x$ and $1 - 3x$

- c. The opposite of $4x$ and $-5 + 4x$
- d. The opposite of $-10t$ and $t - 10t$
- e. The opposite of $(-7 - 4v)$ and $-4v$

Example 2

- $\left(\frac{3}{4}\right) \times \left(\frac{4}{3}\right)$
- $4 \times \frac{1}{4}$
- $\frac{1}{9} \times 9$
- $\left(-\frac{1}{3}\right) \times -3$
- $\left(-\frac{6}{5}\right) \times \left(-\frac{5}{6}\right)$

Write the product and then write the expression in standard form by removing parentheses and combining like terms. Justify each step.

- a. The multiplicative inverse of $\frac{1}{5}$ and $(2x - \frac{1}{5})$
- b. The multiplicative inverse of 2 and $(2x + 4)$
- c. The multiplicative inverse of $\left(\frac{1}{3x+5}\right)$ and $\frac{1}{3}$

Exercise 2

Write the product and then write the expression in standard form by removing parentheses and combining like terms. Justify each step.

a. The reciprocal of 3 and $-6y - 3x$

b. The multiplicative inverse of 4 and $4h - 20$

c. The multiplicative inverse of $-\frac{1}{6}$ and $2 - \frac{1}{6}j$

Problem Set

1. Fill in the missing parts of the worked out expressions.

a. The sum of $6c - 5$ and the opposite of $6c$

$$(6c - 5) + (-6c)$$

Rewrite subtraction as addition

$$6c + (-6c) + (-5)$$

$$0 + (-5)$$

Additive Identity Property of Zero

b. The product of $-2c + 14$ and the multiplicative inverse of -2

$$(-2c + 14) \left(-\frac{1}{2}\right)$$

$$(-2c) \left(-\frac{1}{2}\right) + (14) \left(-\frac{1}{2}\right)$$

Multiplicative Inverse, Multiplication

$$1c - 7$$

Adding the Additive Inverse is the same as Subtraction

$$c - 7$$

2. Write the sum and then rewrite the expression in standard form by removing parentheses and collecting like terms.

a. 6 and $p - 6$

b. $10w + 3$ and -3

c. $-x - 11$ and the opposite of -11

d. The opposite of $4x$ and $3 + 4x$

e. $2g$ and the opposite of $(1 - 2g)$

3. Write the product and then rewrite the expression in standard form by removing parentheses and collecting like terms.

a. $7h - 1$ and the multiplicative inverse of 7

b. The multiplicative inverse of -5 and $10v - 5$

c. $9 - b$ and the multiplicative inverse of 9

d. The multiplicative inverse of $\frac{1}{4}$ and $5t - \frac{1}{4}$

e. The multiplicative inverse of $-\frac{1}{10x}$ and $\frac{1}{10x} - \frac{1}{10}$

4. Write the expressions in standard form.

a. $\frac{1}{4}(4x + 8)$

b. $\frac{1}{6}(r - 6)$

c. $\frac{4}{5}(x + 1)$

d. $\frac{1}{8}(2x + 4)$

e. $\frac{3}{4}(5x - 1)$

f. $\frac{1}{5}(10x - 5) - 3$

Lesson 6: Collecting Rational Number Like Terms

Classwork

Opening Exercise

Do the computations, leaving your answers in simplest/standard form. Show your steps.

1. Terry weighs 40 kg. Janice weighs $2\frac{3}{4}$ kg less than Terry. What is their combined weight?

2. $2\frac{2}{3} - 1\frac{1}{2} - \frac{4}{5}$

3. $\frac{1}{5} + (-4)$

4. $4\left(\frac{3}{5}\right)$

5. Mr. Jackson bought $1\frac{3}{5}$ lbs of beef. He cooked $\frac{3}{4}$ of it for lunch. How much does he have left?

6. $\frac{2}{3}n - \frac{3}{4}n + \frac{1}{6}n + 2\frac{2}{9}n$

Example 1

Rewrite the expression in standard form by collecting like terms.

$$\frac{1}{2}a + 2\frac{2}{3}b + \frac{1}{5} - \frac{1}{4}a - 1\frac{1}{2}b + \frac{3}{5} + \frac{3}{4}a - 4 - \frac{4}{5}b$$

$$\frac{1}{2}a + 2\frac{2}{3}b + \frac{1}{5} + \left(-\frac{1}{4}a\right) + \left(-1\frac{1}{2}b\right) + \frac{3}{5} + \frac{3}{4}a + (-4) + \left(-\frac{4}{5}b\right)$$

Subtraction as adding the inverse

$$\frac{1}{2}a + \left(-\frac{1}{4}a\right) + \frac{3}{4}a + 2\frac{2}{3}b + \left(-1\frac{1}{2}b\right) + \left(-\frac{4}{5}b\right) + \frac{1}{5} + \frac{3}{5} + (-4)$$

Any order property (commutative property)

$$\left(\frac{1}{2} + \left(-\frac{1}{4}\right) + \frac{3}{4}\right)a + \left(2\frac{2}{3} + \left(-1\frac{1}{2}\right) + \left(-\frac{4}{5}\right)\right)b + \left(\frac{4}{5} + (-4)\right)$$

Collecting like terms by applying distributive property

$$a + \frac{11}{30}b - \frac{16}{5}$$

Arithmetic rules for rational numbers

The expression with eight terms can be rewritten with a minimum of three terms.

Exercise 1

For the following exercises, predict how many terms the resulting expression will have after collecting like terms. Then, write the expression in standard form by collecting like terms.

a. $\frac{2}{5}g - \frac{1}{6} - g + \frac{3}{10}g - \frac{4}{5}$

b. $i + 6i - \frac{3}{7}i + \frac{1}{3}h + \frac{1}{2}i - h + \frac{1}{4}h$

Example 2

At a store, a shirt was marked down in price by ten dollars. A pair of pants doubled in price. Following these changes, the price of every item in the store was cut in half. Write two different expressions that represent the new cost of the items, using s for the cost of each shirt and p for the cost of a pair of pants. Explain the different information each one shows.

Exercise 2

Continuing with Example 2, write two different expressions that represent the total cost of the items if tax was $\frac{1}{10}$ of the original price. Explain the different information each shows.

Example 3

As a class, write each expression in standard form by collecting like terms. Justify each step.

$$5\frac{1}{3} - \left(3\frac{1}{3}\right)\left(\frac{1}{2}x - \frac{1}{4}\right)$$

$$\frac{16}{3} + \left(-\frac{10}{3}\right)\left(\frac{1}{2}x\right) + \left(-\frac{10}{3}\right)\left(-\frac{1}{4}\right)$$
 Write mixed numbers as improper fractions, then distribute.

$$\frac{16}{3} + \left(-\frac{5}{3}x\right) + \frac{5}{6}$$
 Any grouping (associative) and arithmetic rules for multiplying rational numbers

$$-\frac{5}{3}x + \left(\frac{32}{6} + \frac{5}{6}\right)$$
 Commutative property and associative property of addition, collect like terms

$$-\frac{5}{3}x + \frac{37}{6}$$
 Apply arithmetic rule for adding rational numbers

Exercise 3

Rewrite the following expressions in standard form by finding the product and collecting like terms.

a. $-6\frac{1}{3} - \frac{1}{2}\left(\frac{1}{2} + y\right)$

b. $\frac{2}{3} + \frac{1}{3}\left(\frac{1}{4}f - 1\frac{1}{3}\right)$

Example 4

Model how to write the expression in standard form using rules of rational numbers.

$$\frac{x}{20} + \frac{2x}{5} + \frac{x+1}{2} + \frac{3x-1}{10}$$

$\frac{\frac{x}{20} + \frac{4(2x)}{20} + \frac{10(x+1)}{20} + \frac{2(3x-1)}{20}}{x + 8x + 10x + 10 + 6x - 2}$ $\frac{25x + 8}{20}$ $\frac{5}{4}x + \frac{2}{5}$	$\frac{1}{20}x + \frac{2}{5}x + \frac{1}{2}x + \frac{1}{2} + \frac{3}{10}x - \frac{1}{10}$ $\left(\frac{1}{20} + \frac{2}{5} + \frac{1}{2} + \frac{3}{10}\right)x + \left(\frac{1}{2} - \frac{1}{10}\right)$ $\left(\frac{1}{20} + \frac{8}{20} + \frac{10}{20} + \frac{6}{20}\right)x + \left(\frac{5}{10} - \frac{1}{10}\right)$ $\frac{5}{4}x + \frac{2}{5}$
--	---

Evaluate the original expression and their answers when $x = 20$. Do you get the same number?

$\frac{\frac{x}{20} + \frac{2x}{5} + \frac{x+1}{2} + \frac{3x-1}{10}}{\frac{20}{20} + \frac{2(20)}{5} + \frac{20+1}{2} + \frac{3(20)-1}{10}}$ $1 + 8 + \frac{21}{2} + \frac{59}{10}$ $9 + \frac{105}{10} + \frac{59}{10}$ $9 + \frac{164}{10}$ $9 + 16\frac{4}{10}$ $25\frac{2}{5}$	$\frac{5}{4}x + \frac{2}{5}$ $\frac{5}{4}(20) + \frac{2}{5}$ $25 + \frac{2}{5}$ $25\frac{2}{5}$
---	---

Exercise 4

Rewrite the following expression in standard form by finding common denominators and collecting like terms.

$$\frac{2h}{3} - \frac{h}{9} + \frac{h-4}{6}$$

Example 5

Rewrite the following expression in standard form.

$$\frac{2(3x - 4)}{6} - \frac{5x + 2}{8}$$

Method 1:

Method 2a:

Method 2b:

Method 3:

$\frac{1(3x - 4)}{3} - \frac{5x + 2}{8}$ $\frac{8(3x - 4)}{24} - \frac{3(5x + 2)}{24}$ $\frac{((24x - 32) - (15x + 6))}{24}$ $\frac{(24x - 32 - 15x - 6)}{24}$ $\frac{9x - 38}{24}$ $\frac{9x}{24} - \frac{38}{24}$ $\frac{3}{8}x - \frac{19}{12}$	$\frac{6x - 8}{6} - \frac{5x + 2}{8}$ $\frac{4(6x - 8)}{24} - \frac{3(5x + 2)}{8}$ $\frac{(24x - 32 - 15x - 6)}{24}$ $\frac{9x - 38}{24}$ $\frac{9x}{24} - \frac{38}{24}$ $\frac{3}{8}x - \frac{19}{12}$	$\frac{6}{6}x - \frac{8}{6} - \frac{5}{8}x - \frac{2}{8}$ $x - \frac{4}{3} - \frac{5x}{8} - \frac{1}{4}$ $1x - \frac{5}{8}x - \frac{4}{3} - \frac{1}{4}$ $\frac{3}{8}x - \frac{16}{12} - \frac{3}{12}$ $\frac{3}{8}x - \frac{19}{12}$	$\frac{1}{3}(3x - 4) - \left(\frac{5x}{8} + \frac{1}{4}\right)$ $x - \frac{4}{3} - \frac{5}{8}x - \frac{1}{4}$ $1x - \frac{5}{8}x - \frac{4}{3} - \frac{1}{4}$ $\frac{3}{8}x - \frac{16}{12} - \frac{3}{12}$ $\frac{3}{8}x - \frac{19}{12}$
--	--	---	---

Exercise 5

Write the following expression in standard form.

$$\frac{2x - 11}{4} - \frac{3(x - 2)}{10}$$

Problem Set

- Write the indicated expressions.
 - $\frac{1}{2}m$ inches in feet.
 - The perimeter of a square with $\frac{2}{3}g$ cm sides.
 - The number of pounds in 9 oz.
 - The average speed of a train that travels x miles in $\frac{3}{4}$ hour.
 - Devin is $1\frac{1}{4}$ years younger than Eli. April is $\frac{1}{5}$ as old as Devin. Jill is 5 years older than April. If Eli is E years old, what is Jill's age in terms of E ?
- Rewrite the expressions by collecting like terms.
 - $\frac{1}{2}k - \frac{3}{8}k$
 - $\frac{2r}{5} + \frac{7r}{15}$
 - $-\frac{1}{3}a - \frac{1}{2}b - \frac{3}{4} + \frac{1}{2}b - \frac{2}{3}b + \frac{5}{6}a$
 - $-p + \frac{3}{5}q - \frac{1}{10}q + \frac{1}{9} - \frac{1}{9}p + 2\frac{1}{3}p$
 - $\frac{5}{7}y - \frac{y}{14}$
 - $\frac{3n}{8} - \frac{n}{4} + 2\frac{n}{2}$
- Rewrite the expressions by using the distributive property and collecting like terms.
 - $\frac{4}{5}(15x - 5)$
 - $\frac{4}{5}\left(\frac{1}{4}c - 5\right)$
 - $2\frac{4}{5}v - \frac{2}{3}\left(4v + 1\frac{1}{6}\right)$
 - $8 - 4\left(\frac{1}{8}r - 3\frac{1}{2}\right)$
 - $\frac{1}{7}(14x + 7) - 5$
 - $\frac{1}{5}(5x - 15) - 2x$
 - $\frac{1}{4}(p + 4) + \frac{3}{5}(p - 1)$
 - $\frac{7}{8}(w + 1) + \frac{5}{6}(w - 3)$
 - $\frac{4}{5}(c - 1) - \frac{1}{8}(2c + 1)$
 - $\frac{2}{3}\left(h + \frac{3}{4}\right) - \frac{1}{3}\left(h + \frac{3}{4}\right)$
 - $\frac{2}{3}\left(h + \frac{3}{4}\right) - \frac{2}{3}\left(h - \frac{3}{4}\right)$
 - $\frac{2}{3}\left(h + \frac{3}{4}\right) + \frac{2}{3}\left(h - \frac{3}{4}\right)$
 - $\frac{k}{2} - \frac{4k}{5} - 3$
 - $\frac{3t+2}{7} + \frac{t-4}{14}$
 - $\frac{9x-4}{10} + \frac{3x+2}{5}$
 - $\frac{3(5g-1)}{4} - \frac{2g+7}{6}$
 - $-\frac{3d+1}{5} + \frac{d-5}{2} + \frac{7}{10}$
 - $\frac{9w}{6} + \frac{2w-7}{3} - \frac{w-5}{4}$
 - $\frac{1+f}{5} - \frac{1+f}{3} + \frac{3-f}{6}$

Lesson 7: Understanding Equations

Classwork

Opening Exercise

Your brother is going to college, so you no longer have to share a bedroom. You decide to redecorate a wall by hanging two new posters on the wall. The wall is 14 feet wide and each poster is four feet wide. You want to place the posters on the wall so that the distance from the edge of each poster to the nearest edge of the wall is the same as the distance between the posters, as shown in the diagram below. Determine that distance.

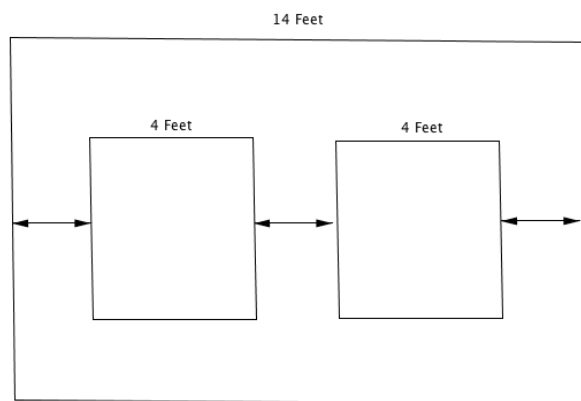

Your parents are redecorating the dining room and want to place two rectangular wall sconce lights that are 25 inches wide along a 10 foot, 8 inch wall, so that the distance between the lights and the distances from each light to the nearest edge of the wall are all the same. Design the wall and determine the distance.

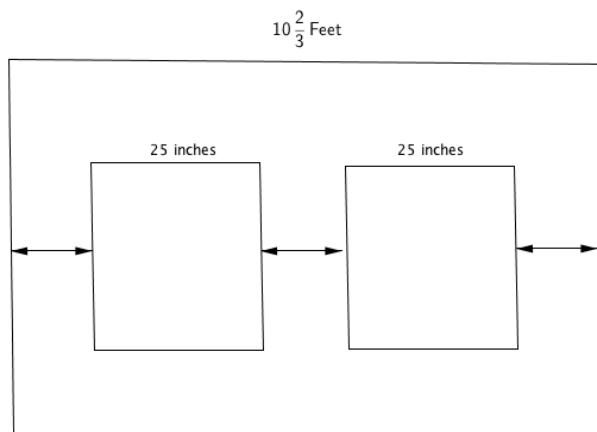

Let the distance between a light and the nearest edge of a wall be x ft. Write an expression in terms of x for the total length of the wall, and then use the expression and the length of the wall given in the problem to write an equation that can be used to find that distance.

Now write an equation where y stands for the number of *inches*: Let the distance between a light and the nearest edge of a wall be y in. Write an expression in terms of y for the total length of the wall, and then use the expression and the length of the wall (in inches) given in the problem to write an equation that can be used to find that distance (in inches).

What value(s) of y makes the second equation true: 24, 25, or 26?

Example 1

The ages of three sisters are consecutive integers. The sum of their ages is 45. Find their ages.

- Use a tape diagram to find their ages.
- If the youngest sister is x years old, describe the ages of the other two sisters in terms of x , write an expression for the sum of their ages in terms of x , and use that expression to write an equation that can be used to find their ages.
- Determine if your answer from part (a) is a solution to the equation you wrote in part (b).

Exercise

1. Sophia pays a \$19.99 membership fee for an online music store.
 - a. If she also buys two songs from a new album at a price of \$0.99 each, what is the total cost?

 - b. If Sophia purchases n songs for \$0.99 each, write an expression for the total cost.

 - c. Sophia's friend has saved \$118 but isn't sure how many songs she can afford if she buys the membership and some songs. Use the expression in part (b) to write an equation that can be used to determine how many songs Sophia's friend can buy.

 - d. Using the equation written in part (c), can Sophia's friend buy 101, 100, or 99 songs?

Relevant Vocabulary

Variable (description): A *variable* is a symbol (such as a letter) that represents a number, i.e., it is a placeholder for a number.

Equation: An *equation* is a statement of equality between two expressions.

Number Sentence: A *number sentence* is a statement of equality between two numerical expressions.

Solution: A *solution* to an equation with one variable is a number that, when substituted for the variable in both expressions, makes the equation a true number sentence.

Lesson Summary

In many word problems, an equation is often formed by setting an expression equal to a number. To build the expression, it is often helpful to consider a few numerical calculations with just numbers first. For example, if a pound of apples costs \$2, then three pounds cost \$6 (2×3), four pounds cost \$8 (2×4), and n pounds cost $2n$ dollars. If we had \$15 to spend on apples and wanted to know how many pounds we could buy, we can use the expression $2n$ to write an equation, $2n = 15$, which can then be used to find the answer: $7\frac{1}{2}$ pounds.

To determine if a number is a solution to an equation, substitute the number into the equation for the variable (letter) and check to see if the resulting number sentence is true. If it is true, then the number is a solution to the equation. For example, $7\frac{1}{2}$ is a solution to $2n = 15$ because $2\left(7\frac{1}{2}\right) = 15$.

Problem Set

1. Check whether the given value is a solution to the equation.

a. $4n - 3 = -2n + 9$ $n = 2$
 b. $9m - 19 = 3m + 1$ $m = \frac{10}{3}$
 c. $3(y + 8) = 2y - 6$ $y = 30$

2. Tell whether each number is a solution to the problem modeled by the following equation.

Mystery Number: Five more than -8 times a number is 29. What is the number?

Let the mystery number be represented by n .

The equation is: $5 + (-8)n = 29$.

- a. Is 3 a solution to the equation? Why or why not?
 b. Is -4 a solution to the equation? Why or why not?
 c. Is -3 a solution to the equation? Why or why not?
 d. What is the mystery number?
3. The sum of three consecutive integers is 36.
- a. Find the smallest integer using a tape diagram.
 b. Let n represent the smallest integer. Write an equation that can be used to find the smallest integer.
 c. Determine if each value of n below is a solution to the equation in part (b).
 $n = 12.5$
 $n = 12$
 $n = 11$

4. Andrew is trying to create a number puzzle for his younger sister to solve. He challenges his sister to find the mystery number. “When 4 is subtracted from half of a number the result is 5.” The equation to represent the mystery number is $\frac{1}{2}m - 4 = 5$. Andrew’s sister tries to guess the mystery number.
- Her first guess is 30. Is she correct? Why or why not?
 - Her second guess is 2. Is she correct? Why or why not?
 - Her final guess is $4\frac{1}{2}$. Is she correct? Why or why not?

Lesson 8: Using If-Then Moves in Solving Equations

Classwork

Opening Exercise

Recall and summarize the if-then moves.

Write $3 + 5 = 8$ in as many true equations as you can using the if-then moves. Identify which if-then move you used.

Example 1

Julia, Keller, and Israel are volunteer firefighters. On Saturday the volunteer fire department held its annual coin drop fundraiser at a streetlight. After one hour, Keller had collected \$42.50 more than Julia, and Israel had collected \$15 less than Keller. Altogether, the three firefighters collected \$125.95. How much did each person collect?

Find the solution using a tape diagram.

What were the operations we used to get our answer?

The amount of money Julia collected is j dollars. Write an expression to represent the amount of money Keller collected in dollars.

Using the expressions for Julia and Keller, write an expression to represent the amount of money Israel collected in dollars.

Using the expressions written above, write an equation in terms of j that can be used to find the amount each person collected.

Solve the equation written above to determine the amount of money each person collected and describe any if-then moves used.

Example 2

You are designing a rectangular pet pen for your new baby puppy. You have 30 feet of fence barrier. On a whim, you decide that you would like the length to be $6\frac{1}{3}$ feet longer than the width.

Draw and label a diagram to represent the pet pen. Write expressions to represent the width and length of the pet pen.

Find the dimensions of the pet pen.

Example 3

Nancy's morning routine involves getting dressed, eating breakfast, making her bed, and driving to work. Nancy spends $\frac{1}{3}$ of the total time in the morning getting dressed, 10 minutes eating breakfast, 5 minutes making her bed and the remaining time driving to work. If Nancy spent $35\frac{1}{2}$ minutes getting dressed, eating breakfast, and making her bed, how long was her drive to work?

Write and solve this problem using an equation. Identify the if-then moves used when solving the equation.

Is your answer reasonable? Explain.

Example 4

The total number of participants who went on the 6th grade field trip to the Natural Science Museum consisted of all of the 6th grade students and 7 adult chaperones. $\frac{2}{3}$ of the total participants rode a large bus and the rest rode a smaller bus. If **54** of them rode the large bus, how many students went on the field trip?

Lesson Summary

Algebraic Approach: To “solve an equation” algebraically means to use the properties of operations and if-then moves to simplify the equation into a form where the solution is easily recognizable. For the equations we are studying this year (called linear equations), that form is an equation that looks like, $x = \text{“a number,”}$ where the number is the solution.

If-then moves: If x is a solution to an equation, it will continue to be a solution to the new equation formed by adding or subtracting a number from both sides of the equation. It will also continue to be a solution when both sides of the equation are multiplied by or divided by a non-zero number. We use these if-then moves to make 0s and 1s in ways that simplify the original equation.

Useful First Step: If one is faced with the task of finding a solution to an equation, a useful first step is to collect like terms on each side of the equation.

Problem Set

Write and solve an equation for each problem.

1. The perimeter of a rectangle is 30 inches. If its length is three times its width, find the dimensions.

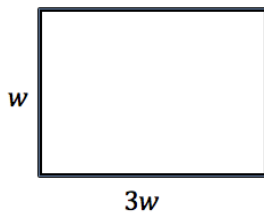

2. A cell phone company has a basic monthly plan of \$40 plus \$0.45 for any minutes used over 700. Before receiving his statement, John saw he was charged a total of \$48.10. Write and solve an equation to determine how many minutes he must have used during the month. Write an equation without decimals.
3. A volleyball coach plans her daily practices to include 10 minutes of stretching, $\frac{2}{3}$ of the entire practice scrimmaging, and the remaining practice time working on drills of specific skills. On Wednesday, the coach planned 100 minutes of stretching and scrimmaging. How long, in hours, is the entire practice?
4. The sum of two consecutive even numbers is 54. Find the numbers.
5. Justin has \$7.50 more than Eva and Emma has \$12 less than Justin does. How much money does each person have if they have a total of \$63?

6. Barry's mountain bike weighs 6 pounds more than Andy's. If their bikes weigh 42 pounds altogether, how much does Barry's bike weigh? Identify the if-then moves in your solution.
7. Trevor and Marissa together have 26 t-shirts to sell. If Marissa has 6 fewer t-shirts than Trevor, find how many t-shirts Trevor has. Identify the if-then moves in your solution.
8. A number is $\frac{1}{7}$ of another number. The difference of the numbers is 18. (Assume that you are subtracting the smaller number from the larger number.) Find the numbers.
9. A number is 6 greater than $\frac{1}{2}$ another number. If the sum of the numbers is 21, find the numbers.
10. Kevin is twice as old now as his brother is. If Kevin was 8 years old 2 years ago, how old is Kevin's brother now?
11. The sum of two consecutive odd numbers is 156. What are the numbers?
12. If n represents an odd integer, write expressions in terms of n that represent the next three consecutive odd integers. If the four consecutive odd integers have a sum of 56, find the numbers.
13. Six times the sum of three consecutive odd integers is -18 . Find the integers.
14. I am thinking of a number. If you multiply my number by 4, add -4 to the product, then take $\frac{1}{3}$ of the sum, the result is -6 . Find my number.
15. A vending machine has twice as many quarters in it as dollar bills. If the quarters and dollar bills have a combined value of \$96, how many quarters are in the machine?

Lesson 9: Using If-Then Moves in Solving Equations

Classwork

Opening Exercise

Every day Heather practices soccer and piano. Each day she practices piano for 2 hours. If after 5 days she practiced both piano and soccer for a total of 20 hours, how many hours, h , per day did Heather practice soccer?

Every day for 5 days, Jake practices soccer. Over the 5 days, he also practices piano for a total of 2 hours. If he practiced piano and soccer for a total of 20 hours, how many hours, h , per day did Jake practice soccer?

Example 1

Fred and Sam are a team in the local 138.2 mile bike-run-athon. Fred will compete in the bike race and Sam will compete in the run. Fred biked at an average speed of 8 miles per hour and Sam ran at an average speed of 4 miles per hour. The bike race began at 6:00 a.m. followed by the run. Sam finished the run at 2:33 a.m. the next morning.

- How many hours did it take for them to complete the entire bike-run-athon?
- If t is how long it took for Fred to complete the bike race, in hours, write an expression to find Fred's total distance.

- c. Write an expression, in terms of t to express Sam's time.
- d. Write an expression, in terms of t , that express Sam's total distance.
- e. Write and solve an equation using the total distance both Fred and Sam traveled.
- f. How far did Fred bike and how much time did it take him to complete his leg of the race?

g. How far did Sam run and how much time did it take him to complete his leg of the race?

Total Time (hours)	Fred's Time (hours)	Sam's Time (hours)
10	6	
15	12	
20	8	
18.35	8	
20.55	t	

Example 2

Shelby is seven times as old as Bonnie. If in 5 years, the sum of Bonnie and Shelby's ages is 98, find Bonnie's present age. Use an algebraic approach.

Problem Set

1. A company buys a digital scanner for \$12,000. The value of the scanner is $1,200\left(1 - \frac{n}{5}\right)$ after n years. They have budgeted to replace the scanner redeeming a trade-in value of \$2,400. After how many years should they plan to replace the machine in order to receive this trade-in value?
2. Michael is 17 years older than John. In 4 years, the sum of their ages will be 49. Find Michael's present age.
3. Brady rode his bike 70 miles in 4 hours. He rode at an average speed of 17 mph for t hours and at an average rate of speed of 22 mph for rest of the time. How long did Brady ride at the slower speed? t represents the time, in hours, Brady rode at 17 mph.
4. Caitlan went to the store to buy school clothes. She had a store credit from a previous return in the amount of \$39.58. If she bought 4 of the same style shirt in different colors and spent a total of \$52.22, what was the price of each shirt she bought? Write and solve an equation with integer coefficients.
5. A young boy is growing at a rate of 3.5 cm per month. He is currently 90 cm tall. At that rate, in how many months will the boy grow to a height of 132 cm?
6. The sum of a number, $\frac{1}{6}$ of that number, $2\frac{1}{2}$ of that number, and 7 is $2\frac{1}{2}$. Find the number.
7. The sum of two numbers is 33 and their difference is 2. Find the numbers.
8. Aiden refills three token machines in an arcade. He puts twice the number of tokens in machine A as in machine B , and in machine C , he puts $\frac{3}{4}$ what he put in machine A . The three machines took a total of 18,324 tokens. How many did each machine take?
9. Paulie ordered 250 pens and 250 pencils to sell for a theatre club fundraiser. The pens cost 11 cents more than the pencils. If Paulie's total order cost \$42.50, find the cost of each pen and pencil.
10. A family left their house in two cars at the same time. One car traveled an average of 7 miles per hour faster than the other. When the first car arrived at the destination after $5\frac{1}{2}$ hours of driving, both cars had driven 599.5 miles. If the second car continues at the same average speed, how much time to the nearest minute before the second car arrives?
11. Emily counts the triangles and parallelograms in an art piece and determines that there are altogether 42 triangles and parallelograms. If there are 150 total sides, how many triangles and parallelograms are there?

12. Stefan is three years younger than his sister Katie. The sum of Stefan's age 3 years ago and $\frac{2}{3}$ of Katie's age at that time was 12. How old is Katie now?
13. Lucas bought a certain weight of oats for his horse at a unit price of \$0.20 per pound. The total cost of the oats left him with \$1. He wanted to buy the same weight of enriched oats instead, but at \$0.30 per pound, he would have been \$2 short of the total amount due. How much money did Lucas have to buy oats?
14. A store is selling bundles of recordable compact discs (CD-R) and rewriteable compact discs (CD-RW). Each bundle contains the same number of discs. The store has advertised 15 CD-Rs for \$1 and 10 CD-RWs for \$1. Doug has exactly enough money to buy 6 bundles of CD-RWs and 1 bundle of CD-Rs. Buying 7 bundles of CD-RWs would have left him \$2 short of the amount due. How many discs are in each bundle?

Lesson 10: Angle Problems and Solving Equations

Classwork

Angle Facts and Definitions

Name of Angle Relationship	Angle Fact	Diagram
Adjacent Angles		
Vertical Angles (vert. \angle s)		
Angles on a Line (\angle s on a line)		
Angles at a Point (\angle s at a point)		

Opening Exercise

Use a protractor, measure all the angles and complete the chart to follow.

	Name the Angles that are
Vertical	
Adjacent	
Angles on a Line	
Angles at a Point	

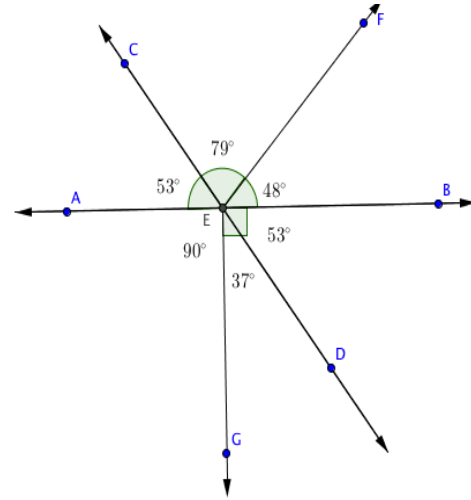

Example 1

Estimate the measurement of x . ___

In a complete sentence, describe the angle relationship in the diagram.

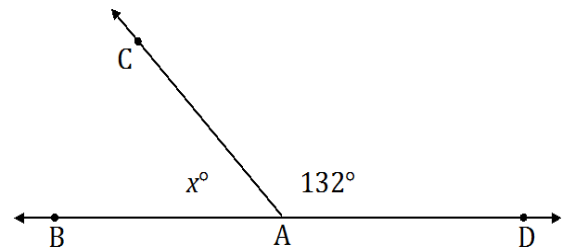

Write an equation for the angle relationship shown in the figure and solve for x . Then find the measures of $\angle BAC$ and confirm your answers by measuring the angle with a protractor.

Exercise 1

In a complete sentence, describe the angle relationship in the diagram.

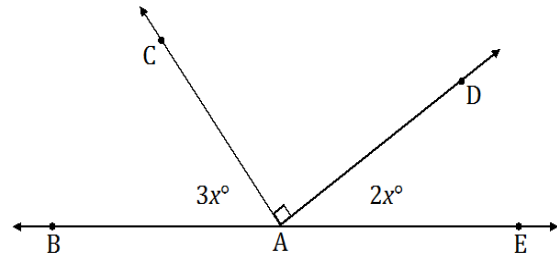

Find the measurements of $\angle BAC$ and $\angle DAE$.

Example 2

In a complete sentence, describe the angle relationship in the diagram.

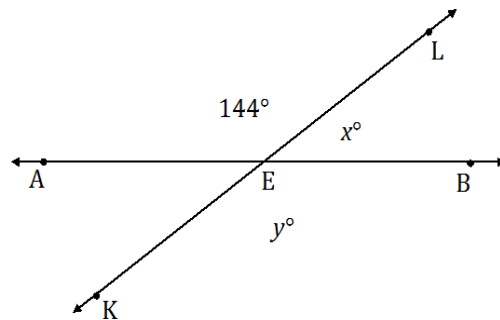

Write an equation for the angle relationship shown in the figure and solve for x and y . Find the measurements of $\angle LEB$ and $\angle KEB$.

Exercise 2

In a complete sentence, describe the angle relationships in the diagram.

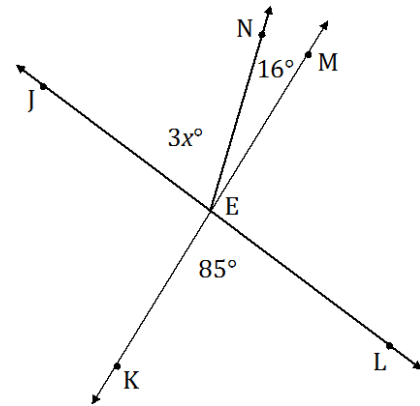

Write an equation for the angle relationship shown in the figure and solve for x .

Example 3

In a complete sentence, describe the angle relationships in the diagram.

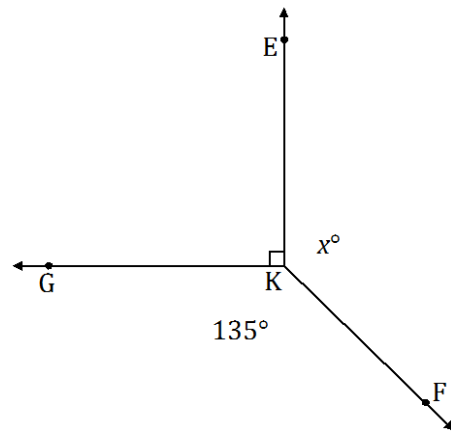

Write an equation for the angle relationship shown in the figure and solve for x . Find the measurement of $\angle EKF$ and confirm your answers by measuring the angle with a protractor.

Exercise 3

In a complete sentence, describe the angle relationships in the diagram.

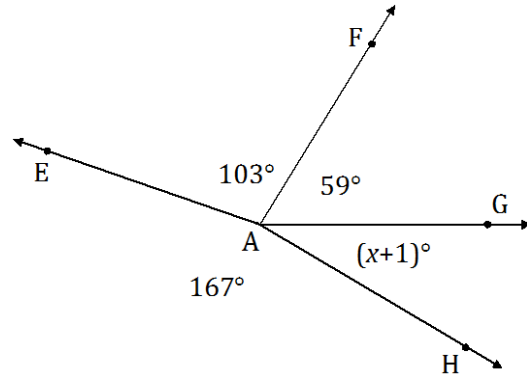

Find the measurement of $\angle GAH$.

Example 4

Two lines intersect in the following figure. In the figure, the ratio of the measurements of the obtuse angle to the acute angle in any adjacent angle pair is 2:1. In a complete sentence, describe the angle relationships in the diagram.

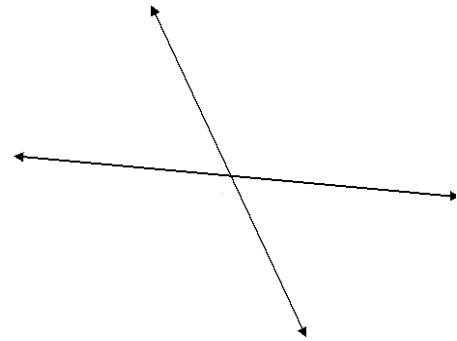

Label the diagram with expressions that describe this relationship. Write an equation that models the angle relationship and solve for x . Find the measurements of the acute and obtuse angles.

Exercise 4

The ratio of $\angle GFH$ to $\angle EFH$ is 2:3. In a complete sentence, describe the angle relationships in the diagram.

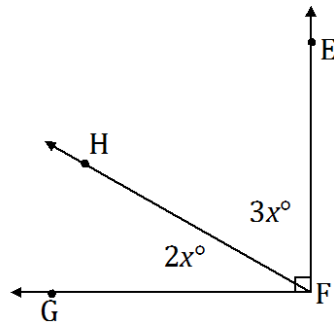

Find the measures of $\angle GFH$ and $\angle EFH$.

Relevant Vocabulary

Adjacent Angles: Two angles $\angle BAC$ and $\angle CAD$ with a common side \overrightarrow{AC} are adjacent angles if C belongs to the interior of $\angle BAD$.

Vertical Angles: Two angles are *vertical angles* (or *vertically opposite angles*) if their sides form two pairs of opposite rays.

Angles on a Line: The sum of the measures of adjacent angles on a line is 180° .

Angles at a Point: The sum of the measures of adjacent angles at a point is 360° .

Problem Set

For each question, use angle relationships to write an equation in order to solve for each variable. Determine the indicated angles. You can check your answers by measuring each angle with a protractor.

- In a complete sentence, describe the relevant angle relationships in the following diagram. Find the measurement of $\angle DAE$.

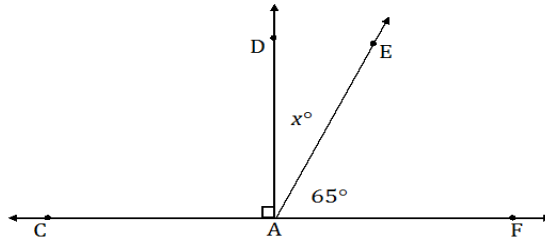

- In a complete sentence, describe the relevant angle relationships in the following diagram. Find the measurement of $\angle QPR$.

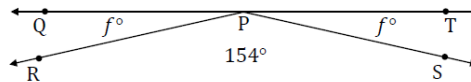

- In a complete sentence, describe the relevant angle relationships in the following diagram. Find the measurements of $\angle CQD$ and $\angle EQF$.

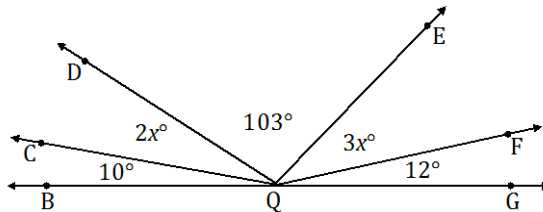

- In a complete sentence, describe the relevant angle relationships in the following diagram. Find the measure of x .

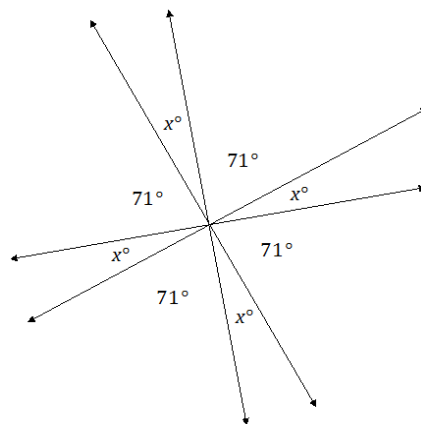

5. In a complete sentence, describe the relevant angle relationships in the following diagram. Find the measure of x and y .

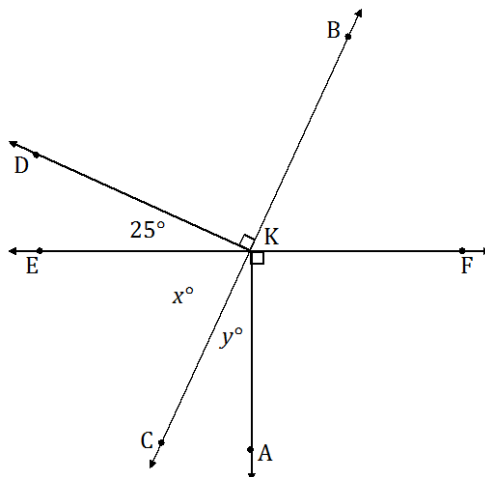

6. In a complete sentence, describe the relevant angle relationships in the following diagram. Find the measure of x and y .

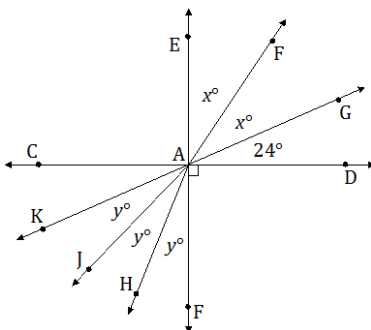

7. In a complete sentence, describe the relevant angle relationships in the following diagram. Find the measure of $\angle CAD$ and $\angle DAE$.

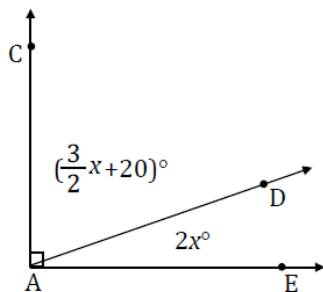

8. In a complete sentence, describe the relevant angle relationships in the following diagram. Find the measure of $\angle CQG$.

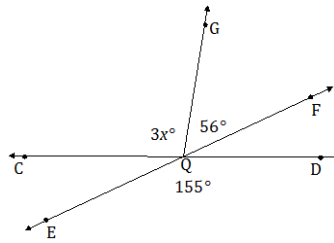

9. The ratio of the measures of a pair of adjacent angles on a line is 4:5.
- Find the measures of the two angles.
 - Draw a diagram to scale of these adjacent angles. Indicate the measurements of each angle.
10. The ratio of the measures of three adjacent angles on a line is 3:4:5. Find the measures of the three angles.
- Find the measures of the three angles.
 - Draw a diagram to scale of these adjacent angles. Indicate the measurements of each angle.

Lesson 11: Angle Problems and Solving Equations

Classwork

Opening Exercise

- a. In a complete sentence, describe the angle relationship in the diagram. Write an equation for the angle relationship shown in the figure and solve for x . Confirm your answers by measuring the angle with a protractor.

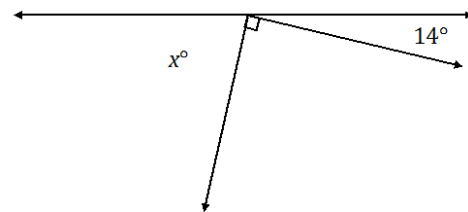

- b. CD and EF are intersecting lines. In a complete sentence, describe the angle relationship in the diagram. Write an equation for the angle relationship shown in the figure and solve for y . Confirm your answers by measuring the angle with a protractor.

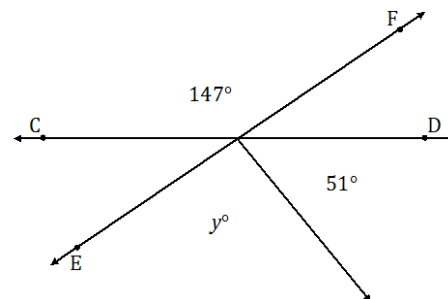

- c. In a complete sentence, describe the angle relationship in the diagram. Write an equation for the angle relationship shown in the figure and solve for y . Confirm your answers by measuring the angle with a protractor.

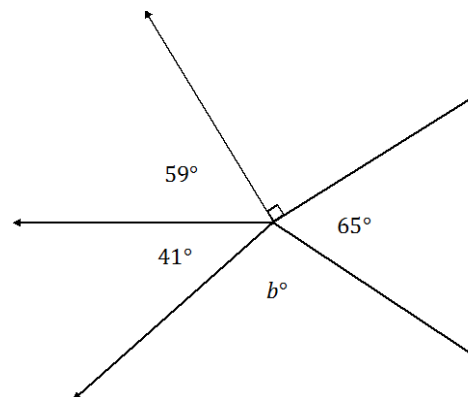

- d. The following figure shows three lines intersecting at a point. In a complete sentence, describe the angle relationship in the diagram. Write an equation for the angle relationship shown in the figure and solve for z . Confirm your answers by measuring the angle with a protractor.

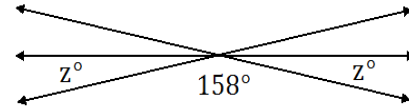

- e. Write an equation for the angle relationship shown in the figure and solve for x . In a complete sentence, describe the angle relationship in the diagram. Find the measurements of $\angle EPB$ and $\angle CPA$. Confirm your answers by measuring the angle with a protractor.

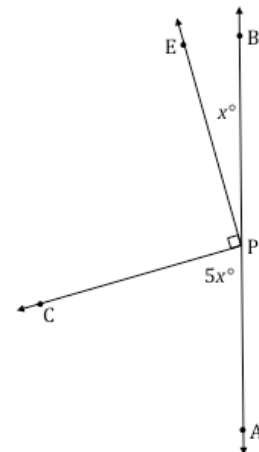

Example 1

The following figure shows three lines intersecting at a point. In a complete sentence, describe the angle relationship in the diagram. Write an equation for the angle relationship shown in the figure and solve for x . Confirm your answers by measuring the angle with a protractor.

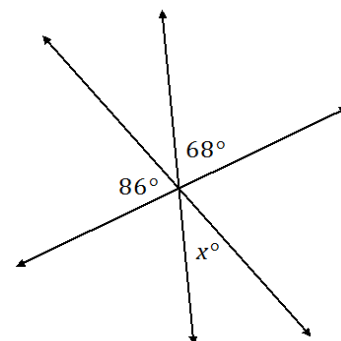

Exercise 1

The following figure shows four lines intersecting at a point. In a complete sentence, describe the angle relationships in the diagram. Write an equation for the angle relationship shown in the figure and solve for x and y . Confirm your answers by measuring the angle with a protractor.

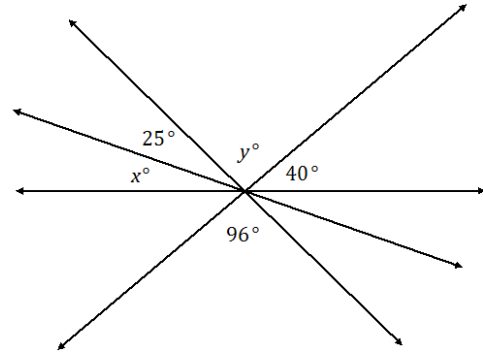

Example 2

In a complete sentence, describe the angle relationships in the diagram. You may label the diagram to help describe the angle relationships. Write an equation for the angle relationship shown in the figure and solve for x . Confirm your answers by measuring the angle with a protractor.

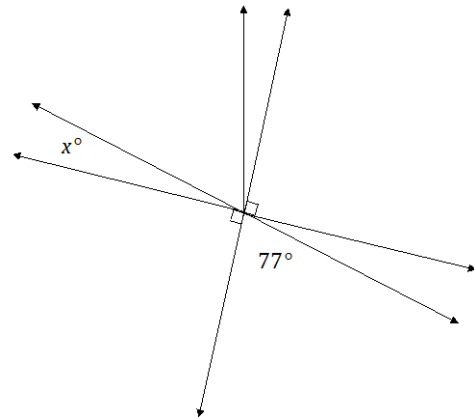

Exercise 2

In a complete sentence, describe the angle relationships in the diagram. Write an equation for the angle relationship shown in the figure and solve for x and y . Confirm your answers by measuring the angle with a protractor.

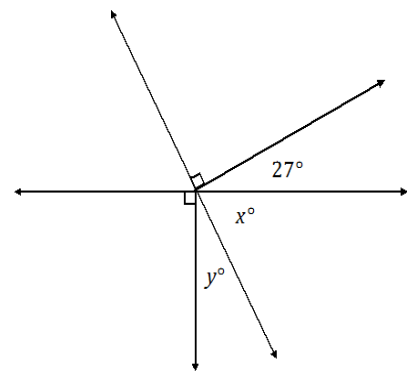

Example 3

In a complete sentence, describe the angle relationships in the diagram. Write an equation for the angle relationship shown in the figure and solve for x . Find the measures of $\angle JAH$ and $\angle GAF$. Confirm your answers by measuring the angle with a protractor.

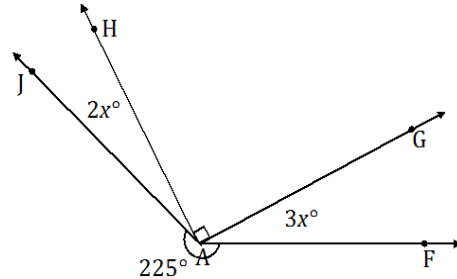

Exercise 3

In a complete sentence, describe the angle relationships in the diagram. Write an equation for the angle relationship shown in the figure and solve for x . Find the measure of $\angle JKG$. Confirm your answers by measuring the angle with a protractor.

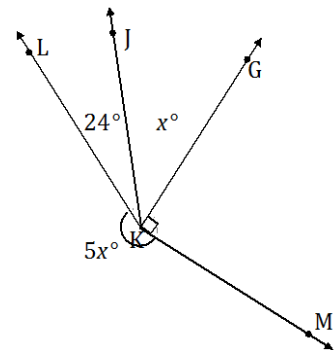

Example 4

In the accompanying diagram, $\angle DBE$ is four times the measure of $\angle FBG$.

- a. Label $\angle DBE$ as y° and $\angle FBG$ as x° . Write an equation that describes the relationship between $\angle DBE$ and $\angle FBG$.

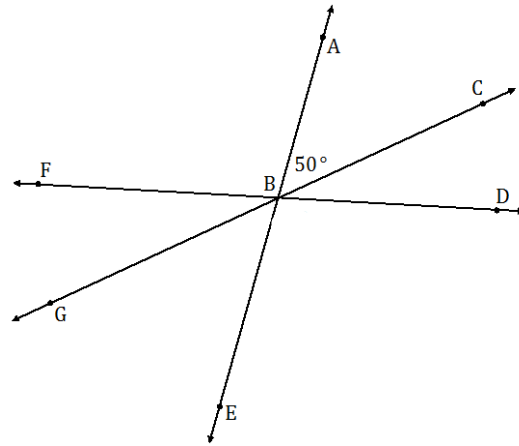

- b. Find the value of x .

- c. Find the measures of $\angle FBG$, $\angle CBD$, $\angle ABF$, $\angle GBE$, $\angle DBE$.

- d. What is the measure of $\angle ABG$? Identify the angle relationship used to get your answer.

Problem Set

In a complete sentence, describe the angle relationships in each diagram. Write an equation for the angle relationship(s) shown in the figure, and solve for the indicated unknown angle. You can check your answers by measuring each angle with a protractor.

1. Find the measure of $\angle EAF$, $\angle DAE$, and $\angle CAD$.

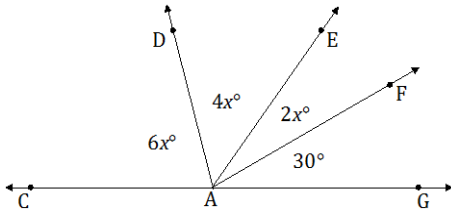

2. Find the measure of a .

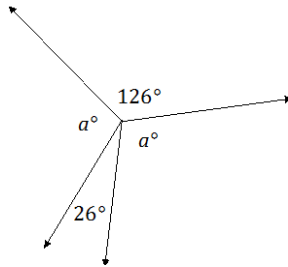

3. Find the measure of x and y .

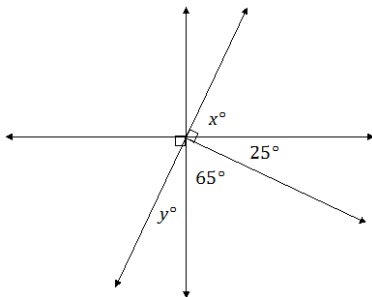

4. Find the measure of $\angle HAJ$.

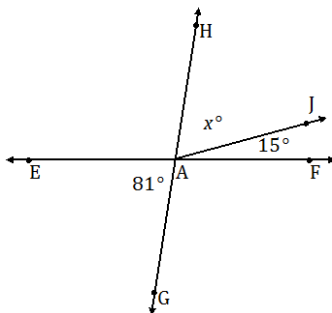

5. Find the measure of $\angle HAB$ and $\angle CAB$.

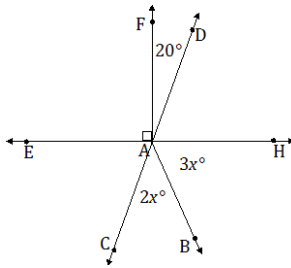

6. The measure of $\angle SPT = b^\circ$. The measure of $\angle TPR$ is five more than two times $\angle SPT$. The measure of $\angle QPS$ is twelve less than eight times $\angle SPT$. Find the measures of $\angle SPT$, $\angle TPR$, and $\angle QPS$.

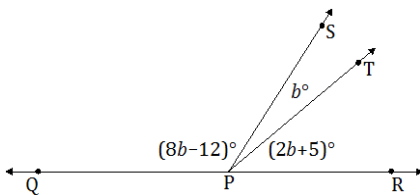

7. Find the measure of $\angle HQE$ and $\angle AQG$.

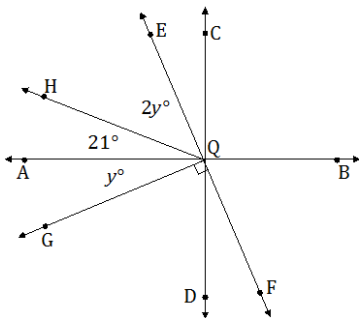

8. The measures of three angles at a point are in the ratio of 2:3:5. Find the measures of the angles.
9. The sum of the measures of two adjacent angles is 72° . The ratio of the smaller angle to the larger angle is 1:3. Find the measures of each angle.
10. Find the measure of $\angle CQA$ and $\angle EQB$.

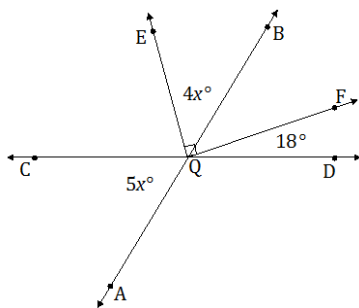

Lesson 12: Properties of Inequalities

Classwork

Example 1

Preserves the inequality symbol:

Reverses the inequality symbol:

Station 1

Die 1	Inequality	Die 2	Operation	New Inequality	Inequality Symbol Preserved or Reversed?
-3	<	5	Add 2	$-3 + 2 < 5 + 2$ $-1 < 7$	Preserved
			Add -3		
			Subtract 2		
			Subtract -1		
			Add 1		

Examine the results. Make a statement about what you notice, and justify it with evidence.

Station 2

Die 1	Inequality	Die 2	Operation	New Inequality	Inequality Symbol Preserved or Reversed?
-3	<	4	Multiply by -1	$(-1)(-3) < (-1)(4)$ $3 < -4$ $3 > -4$	Reversed
			Multiply by -1		
			Multiply by -1		
			Multiply by -1		
			Multiply by -1		

Examine the results. Make a statement about what you notice and justify it with evidence.

Station 3

Die 1	Inequality	Die 2	Operation	New Inequality	Inequality Symbol Preserved or Reversed?
-2	>	-4	Multiply by $\frac{1}{2}$	$(-2)\left(\frac{1}{2}\right) > (-4)\left(\frac{1}{2}\right)$ $-1 > -2$	Preserved
			Multiply by 2		
			Divide by 2		
			Divide by $\frac{1}{2}$		
			Multiply by 3		

Examine the results. Make a statement about what you notice, and justify it with evidence.

Station 4

Die 1	Inequality	Die 2	Operation	New Inequality	Inequality Symbol Preserved or Reversed?
3	$>$	-2	Multiply by -2	$3(-2) > (-2)(-2)$ $-6 < 4$	Reversed
			Multiply by -3		
			Divide by -2		
			Divide by $-\frac{1}{2}$		
			Multiply by $-\frac{1}{2}$		

Examine the results. Make a statement about what you notice and justify it with evidence.

Exercises

Complete the following chart using the given inequality, and determine an operation in which the inequality symbol is preserved and an operation in which the inequality symbol is reversed. Explain why this occurs.

Inequality	Operation and New Inequality Which Preserves the Inequality Symbol	Operation and New Inequality Which Reverses the Inequality Symbol	Explanation
$2 < 5$			
$-4 > -6$			
$-1 \leq 2$			
$-2 + (-3) < -3 - 1$			

Problem Set

- For each problem, use the properties of inequalities to write a true inequality statement. Two integers are -2 and -5 .
 - Write a true inequality statement.
 - Subtract -2 from each side of the inequality. Write a true inequality statement.
 - Multiply each number by -3 . Write a true inequality statement.
- In science class, Melinda and Owen are experimenting with solids that disintegrate after an initial reaction. Melinda's sample has a mass of 155 grams, and Owen's sample has a mass of 180 grams. After one minute, Melinda's sample lost one gram and Owen's lost three grams. For each of the next ten minutes, Melinda's sample lost one gram per minute and Owen's lost three grams per minute.
 - Write an inequality comparing the two sample's masses after one minute.
 - Write an inequality comparing the two masses after four minutes.
 - Explain why the inequality symbols were preserved.
- On a recent vacation to the Caribbean, Kay and Tony wanted to explore the ocean elements. One day they went in a submarine 150 feet below sea level. The second day they went scuba diving 75 feet below sea level.
 - Write an inequality comparing the submarine's elevation and the scuba diving elevation.
 - If they only were able to go one-fifth of the capable elevations, write a new inequality to show the elevations they actually achieved.
 - Was the inequality symbol preserved or reversed? Explain.
- If a is a negative integer, then which of the number sentences below is true? If the number sentence is not true, give a reason.

a. $5 + a < 5$	b. $5 + a > 5$
c. $5 - a > 5$	d. $5 - a < 5$
e. $5a < 5$	f. $5a > 5$
g. $5 + a > a$	h. $5 + a < a$
i. $5 - a > a$	j. $5 - a < a$
k. $5a > a$	l. $5a < a$

Lesson 13: Inequalities

Classwork

Opening Exercise: Writing Inequality Statements

Tarik is trying to save \$265.49 to buy a new tablet. Right now he has \$40 and can save \$38 a week from his allowance.

Write and evaluate an expression to represent the amount of money saved after:

2 weeks

3 weeks

4 weeks

5 weeks

6 weeks

7 weeks

8 weeks

When will Tarik have enough money to buy the tablet?

Write an inequality that will generalize the problem.

Example 1: Evaluating Inequalities—Finding a Solution

The sum of two consecutive odd integers is more than -12 . Form true numerical inequality expressions.

Write an inequality that will find all values that will make the inequality true.

The sum of two consecutive odd integers is more than -12 . What is the smallest value that will make this true?

- Write an inequality that can be used to find the smallest value that will make the statement true.
- Use If-then moves to solve the inequality written in part a. Identify where the 0's and 1's were made using the If-then moves.

Exercises

- Connor went to the county fair with a \$22.50 in his pocket. He bought a hot dog and drink for \$3.75 and then wanted to spend the rest of his money on ride tickets which cost \$1.25 each.
 - Write an inequality to represent the total spent where r is the number of tickets purchased.
 - Connor wants to use this inequality to determine whether he can purchase 10 tickets. Use substitution to show whether or not he will have enough money.
 - What is the total maximum number of tickets he can buy based upon the given information?
- Write and solve an inequality statement to represent the following problem:
On a particular airline, checked bags can weigh no more than 50 pounds. Sally packed 32 pounds of clothes and five identical gifts in a suitcase that weigh 8 pounds. Write an inequality to represent this situation.

Problem Set

1. Match each problem to the inequality that models it. One choice will be used twice.
- | | | | |
|-------|--|----|-------------------|
| _____ | The sum of three times a number and -4 is greater than 17. | a. | $3x + -4 \geq 17$ |
| _____ | The sum of three times a number and -4 is less than 17. | b. | $3x + -4 < 17$ |
| _____ | The sum of three times a number and -4 is at most 17. | c. | $3x + -4 > 17$ |
| _____ | The sum of three times a number and -4 is no more than 17. | d. | $3x + -4 \leq 17$ |
| _____ | The sum of three times a number and -4 is at least 17. | | |
2. If x represents a positive integer, find the solutions to the following inequalities.
- | | | | |
|----|-----------------------|----|--------------------|
| a. | $x < 7$ | b. | $x - 15 < 20$ |
| c. | $x + 3 \leq 15$ | d. | $-x > 2$ |
| e. | $10 - x > 2$ | f. | $-x \geq 2$ |
| g. | $\frac{x}{3} < 2$ | h. | $-\frac{x}{3} > 2$ |
| i. | $3 - \frac{x}{4} > 2$ | | |
3. Recall that the symbol \neq means "not equal to." If x represents a positive integer, state whether each of the following statements is true or false.
- | | | | |
|----|-------------|----|------------|
| a. | $x > 0$ | b. | $x < 0$ |
| c. | $x > -5$ | d. | $x > 1$ |
| e. | $x \geq 1$ | f. | $x \neq 0$ |
| g. | $x \neq -1$ | h. | $x \neq 5$ |
4. Twice the smaller of two consecutive integers increased by the larger integer is at least 25. Model the problem with an inequality, and determine which of the given values 7, 8, and/or 9 are solutions. Then find the smallest number that will make the inequality true.

5. a. The length of a rectangular fenced enclosure is 12 feet more than the width. If Farmer Dan has 100 feet of fencing, write an inequality to find the dimensions of the rectangle with the largest perimeter that can be created using 100 feet of fencing.
- b. What are the dimensions of the rectangle with the largest perimeter? What is the area enclosed by this rectangle
6. At most, Kyle can spend \$50 on sandwiches and chips for a picnic. He already bought chips for \$6 and will buy sandwiches that cost \$4.50 each. Write and solve an inequality to show how many sandwiches he can buy. Show your work and interpret your solution.

Lesson 14: Solving Inequalities

Classwork

Opening Exercise

The annual County Carnival is being held this summer and will last $5\frac{1}{2}$ days. Use this information and the other given information to answer each problem to follow.

You are the owner of the biggest and newest rollercoaster called the 'Gentle Giant'. The rollercoaster costs \$6 to ride. The operator of the ride must pay \$200 per day for the ride rental and \$65 per day for a safety inspection. If you want to make a profit of at least \$1000 each day, what is the minimum number of people that must ride the rollercoaster to make that profit?

Write an inequality that can be used to find the minimum number of people, p , that must ride the rollercoaster each day to make the daily profit.

Solve the inequality.

Interpret the solution.

Example 1

A youth summer camp has budgeted \$2000 for the campers to attend the carnival. The cost for each camper is \$17.95, which includes general admission to the carnival and 2 meals. The youth summer camp must also pay \$250 for the chaperones to attend the carnival and \$350 for transportation to and from the carnival. What is the greatest amount of campers that can attend the carnival if the camp must stay within their budgeted amount?

Example 2

The carnival owner pays the owner of an exotic animal exhibit \$650 for the entire time the exhibit is displayed. The owner of the exhibit has no other expenses except for a daily insurance cost. If the owner of the animal exhibit wants to make more than \$500 in profits for the $5\frac{1}{2}$ days, what is the greatest daily insurance rate he can afford to pay?

Example 3

There are several vendors at the carnival who sell products and also advertise their businesses. Shane works for a recreational company that sells ATVs, dirt bikes, snowmobiles, and motorcycles. His boss paid him \$500 for working all of the days at the carnival plus 5% commission on all of the sales made at the carnival. What was the minimum amount of sales Shane needed to sell if he earned more than \$1,500?

Lesson Summary

The goal to solving inequalities is to use If-then moves to make 0s and 1s to get the inequality into the form $x >$ a number or $x <$ a number. Adding or subtracting opposites will make 0s. According to the If-then move, a number that is added or subtracted to each side of an inequality does not change the solution of the inequality. Multiplying and dividing numbers makes 1s. A positive number that is multiplied or divided to each side of an inequality does not change the solution of the inequality. However, multiplying or dividing each side of an inequality by a negative number does reverse the inequality sign.

Given inequalities containing decimals, equivalent inequalities can be created which have only integer coefficients and constant terms by repeatedly multiplying every term by ten until all coefficients and constant terms are integers.

Given inequalities containing fractions, equivalent inequalities can be created which have only integer coefficients and constant terms by multiplying every term by the least common multiple of the values in the denominators.

Problem Set

1. As a salesperson, Jonathan is paid \$50 per week plus 3% of the total amount he sells. This week, he wants to earn at least \$100. Write an inequality with integer coefficients for the total sales needed and describe what the solution represents.
2. Systolic blood pressure is the higher number in a blood pressure reading. It is measured as the heart muscle contracts. Heather was with her grandfather when he had his blood pressure checked. The nurse told him that the upper limit of his systolic blood pressure is equal to half his age increased by 110.
 - a. a is the age in years and p is the systolic blood pressure in mmHg (milliliters of Mercury). Write an inequality to represent this situation.
 - b. Heather's grandfather is 76 years old. What is "normal" for his systolic blood pressure?
3. Traci collects donations for a dance marathon. One group of sponsors will donate a total of \$6 for each hour she dances. Another group of sponsors will donate \$75 no matter how long she dances. What number of hours, to the nearest minute, should Traci dance if she wants to raise at least \$1,000?
4. Jack's age is three years more than twice his younger brother's, Jimmy's, age. If the sum of their ages is at most 18, find the greatest age that Jimmy could be.
5. Brenda has \$500 in her bank account. Every week she withdraws \$40 for miscellaneous expenses. How many weeks can she withdraw the money if she wants to maintain a balance of at least \$200?
6. A scooter travels 10 miles per hour faster than an electric bicycle. The scooter traveled for 3 hours, and the bicycle traveled for $5\frac{1}{2}$ hours. All together, the scooter and bicycle travelled no more than 285 miles. Find the maximum speed of each.

Lesson 15: Graphing Solutions to Inequalities

Exercise 1

- Two identical cars need to fit into a small garage. The opening is 23 feet 6 inches wide, and there must be at least 3 feet 6 inches of clearance between the cars and between the edges of the garage. How wide can the cars be?

Example 1

A local car dealership is trying to sell all of the cars that are on the lot. Currently, it has 525 cars on the lot, and the general manager estimates that they will consistently sell 50 cars per week. Estimate how many weeks it will take for the number of cars on the lot to be less than 75.

Write an inequality that can be used to find the number of w full weeks. Since w is the number of full or complete weeks, when $w = 1$ means at the end of week 1.

Solve and graph the inequality.

Interpret the solution in the context of the problem.

Verify the solution.

Exercise 2

2. The cost of renting a car is \$25 per day plus a one time fee of \$75.50 for insurance. How many days can the car be rented if the total cost is to be no more than \$525?
- Write an inequality to model the situation.
 - Solve and graph the inequality.
 - Interpret the solution in the context of the problem.

Additional Exercises

For each problem, write, solve, and graph the inequality, and interpret the solution within the context of the problem.

3. Mrs. Smith decides to buy three sweaters and a pair of jeans. She has \$120 in her wallet. If the price of the jeans is \$35, what is the highest possible price of a sweater?

4. The members of the Select Chorus agree to buy at least 250 tickets for an outside concert. They buy 80 less lawn tickets than balcony tickets. What is the least number of balcony tickets bought?
5. Samuel needs \$29 to download some songs and movies on his iPod. His mother agrees to pay him \$6 an hour for raking leaves in addition to his \$5 weekly allowance. What is the minimum number of hours Samuel must work in one week to have enough money to purchase the songs and movies?

Problem Set

1. Ben has agreed to play less video games and spend more time studying. He has agreed to play less than 10 hours of video games each week. On Monday through Thursday, he plays video games for a total of $5\frac{1}{2}$ hours. For the remaining 3 days, he plays video games for the same amount of time each day. Find t , the amount of time he plays video games, for each of the 3 days. Graph your solution.
2. Gary's contract states that he must work more than 20 hours per week. The graph below represents the number of hours he can work in a week.
 - a. Write an algebraic inequality that representing the number of hours, h , Gary can work in a week.
 - b. Gary gets paid \$15.50 per hour in addition to a weekly salary of \$50. This week he wants to earn more than \$400. Write an inequality to represent this situation.
 - c. Solve and graph the solution form part (b).
3. A bank account has \$650 in it. Every week, Sally withdraws \$50 to pay for her dog sitter. What is the maximum number of weeks that Sally can withdraw the money so there is at least \$75 remaining in the account? Write and solve an inequality to find the solution and graph the solution on a number line.
4. On a cruise ship, there are two options for an internet connection. The first option is a fee of \$5 plus an additional \$0.25 per minute. The second option \$50 for an unlimited number of minutes. For how many minutes, m , is the first option cheaper than the second option? Graph the solution.

Lesson 16: The Most Famous Ratio of All

Classwork

Opening Exercise

- a. Using a compass, draw a circle like the picture to the right.

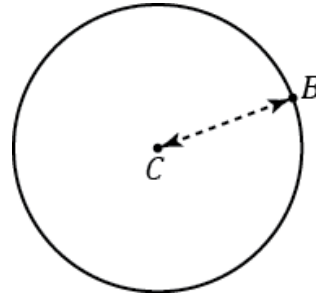

C is the *center* of the circle.

The distance between C and B is the *radius* of the circle.

- b. Write your own definition for the term circle.
- c. Extend segment CB to a segment AB in part (a), where A is also a point on the circle.

The length of the segment AB is called the *diameter of the circle*.

- d. The diameter is _____ as long as radius.

- e. Measure the radius and diameter of each circle. The center of each circle is labeled C .

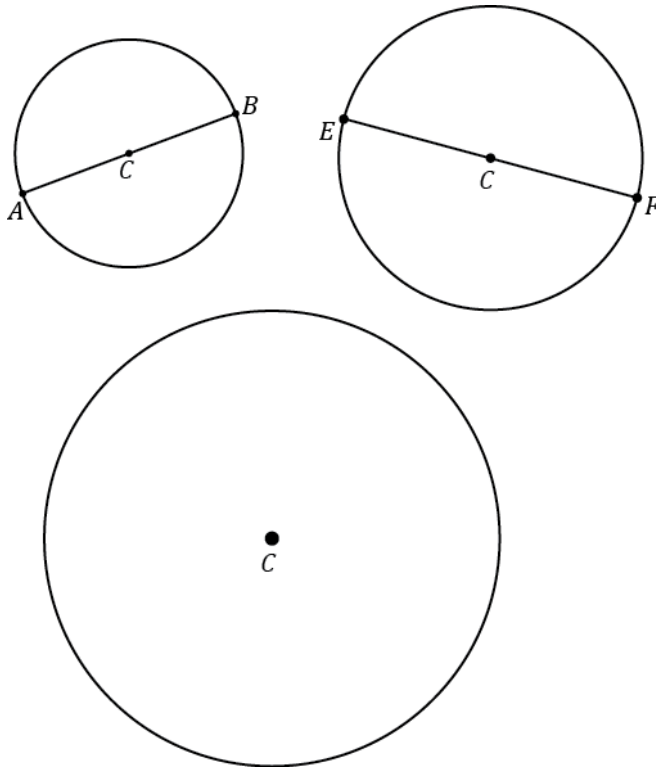

- f. Draw a circle of radius 6 cm.

Example 1

The ratio of the circumference to its diameter is always the same for any circle. The value of this ratio,

$$\frac{\text{Circumference}}{\text{Diameter}}$$

is called the number π and is represented by the symbol π .

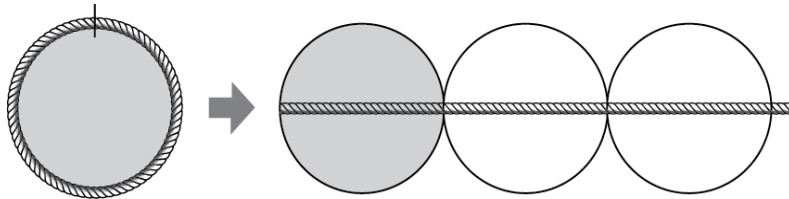

Since the circumference is a little greater than 3 times the diameter, π is a number that is a little greater than 3. State: Use the symbol π to represent this special number. Pi is a non-terminating, non-repeating decimal and mathematicians use the symbol π or approximate representations as more convenient ways to represent pi.

- $\pi \approx 3.14$ or $\frac{22}{7}$.
- The ratios of circumference : diameter and $\pi : 1$ are equal.
- Circumference of a Circle = $\pi \times$ Diameter.

Exercise 2

- a. The following circles are not drawn to scale. Find the circumference of each circle. (Use $\frac{22}{7}$ as an approximation for π .)

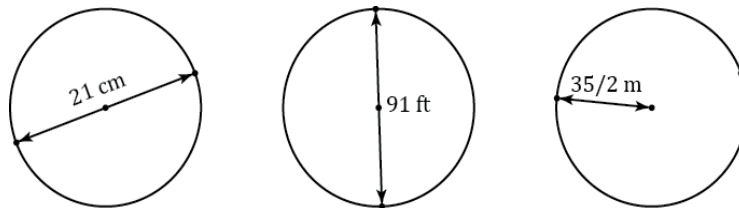

- b. The radius of a paper plate is 11.7 cm. Find the circumference to the nearest tenth. (Use 3.14 as an approximation for π .)

- c. The radius of a paper plate is 11.7 cm. Find the circumference to the nearest hundredth. (Use the π button on your calculator as an approximation for π .)
- d. A circle has a radius of r cm and a circumference of C cm. Write a formula that expresses the value of C in terms of r and π .

- e. The figure below is in the shape of a semicircle. A semicircle is an arc that is “half” of a circle. Find the perimeter of the shape. (Use 3.14 for π .)

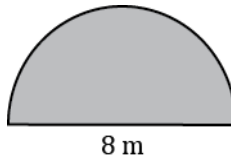

Relevant Vocabulary

Circle: Given a point C in the plane and a number $r > 0$, the *circle with center C and radius r* is the set of all points in the plane that are distance r from the point C .

Radius of a circle: The *radius* is the length of any segment whose endpoints are the center of a circle and a point that lies on the circle.

Diameter of a circle: The *diameter of a circle* is the length of any segment that passes through the center of a circle whose endpoints lie on the circle. If r is the *radius* of a circle, then the diameter is $2r$.

The word *diameter* can also mean the segment itself. Context determines how the term is being used: “the diameter” usually refers to the length of the segment, while “a diameter” usually refers to a segment. Similarly, “a radius” can refer to a segment from the center of a circle to a point on the circle.

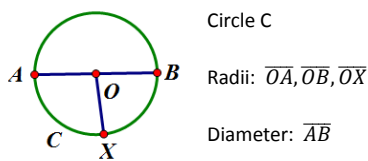

Circumference

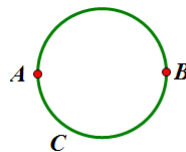

Circumference: The circumference of a circle is the distance around a circle.

Pi: The number *pi*, denoted by π , is the value of the ratio given by the circumference to the diameter, that is $\pi = \frac{\text{circumference}}{\text{diameter}}$. The most commonly used approximations for π is 3.14 or $\frac{22}{7}$.

Semicircle: Let C be a circle with center O , and let A and B be the endpoints of a diameter. A *semicircle* is the set containing A , B , and all points that lie in a given half-plane determined by AB (diameter) that lie on circle C .

Half-plane

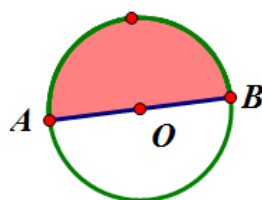

Semi-circle



Problem Set

1. Find the circumference.
 - a. Give an exact answer in terms of π .
 - b. Use $\pi \approx \frac{22}{7}$ and express your answer as a fraction in lowest terms.
 - c. Use *the* π button on your calculator and express your answer to the nearest hundredth.

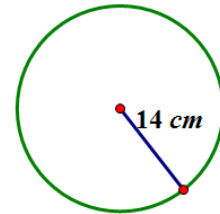

2. Find the circumference.
 - a. Give an exact answer in terms of π .
 - b. Use $\pi \approx \frac{22}{7}$ and express your answer as a fraction in lowest terms.

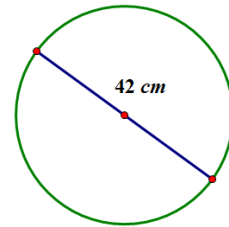

3. The figure shows a circle within a square. Find the circumference of the circle. Let $\pi \approx 3.14$.

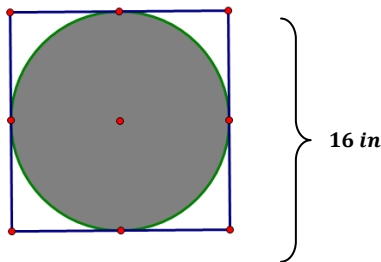

4. Consider the diagram of a semicircle shown.

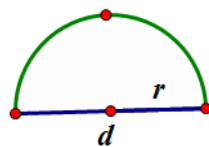

- a. Explain in words how to determine the perimeter of a semicircle.
- b. Using " d " to represent the diameter of the circle, write an algebraic expression that will result in the perimeter of a semicircle.
- c. Write another algebraic expression to represent the perimeter of a semicircle using r to represent the radius of a semicircle.

5. Find the perimeter of the semicircle. Let $\pi \approx 3.14$.

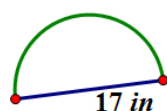

6. Ken’s landscape gardening business makes odd shaped lawns which include semicircles. Find the length of the edging material needed to border the two lawn designs. Use 3.14 for π .

a. The radius of this flower bed is 2.5 m.

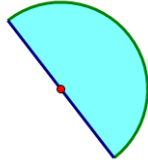

b. The diameter of the semicircular section is 10 m, and the lengths of the sides of the two sides are 6 m.

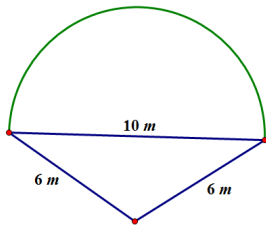

7. Mary and Margaret are looking at a map of a running path in a local park. Which is the shorter path from E to F : along the two semicircles or along the larger semicircle? If one path is shorter, how much shorter is it?

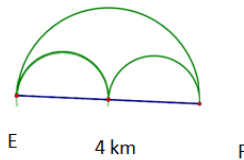

8. Alex the electrician needs 34 yards of electrical wire to complete a job. He has a coil of wiring in his workshop. The coiled up wire is 18 inches in diameter and is made up of 21 circles of wire. Will this coil be enough to complete the job?

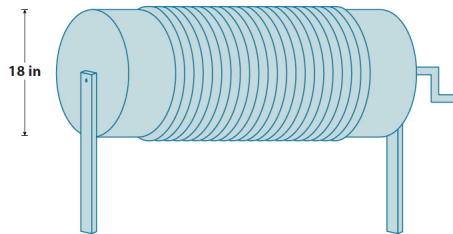

Lesson 17: The Area of a Circle

Classwork

Opening Exercise

Solve the problem below individually. Explain your solution.

1. Find the radius of the following circle if the circumference is 37.68 inches. Use $\pi \approx 3.14$.

2. Determine the area of the rectangle below. Name two ways that can be used to find the area of the rectangle.

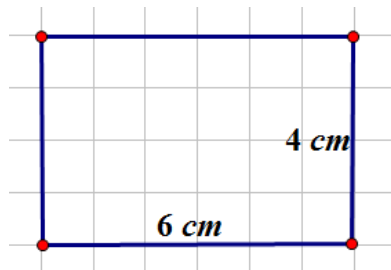

3. Find the length of a rectangle if the area is 27 cm^2 and the width is 3 cm.

Discussion

To find the formula for the area of a circle, cut a circle into 16 equal pieces:

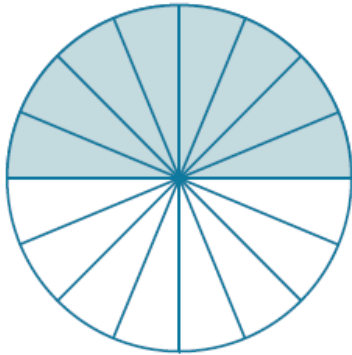

Arrange the triangular wedges by alternating the “triangle” directions and sliding them together to make a “parallelogram.” Cut the triangle on the left side in half on the given line, and slide the outside half of the triangle to the other end of the parallelogram in order to create an approximate “rectangle.”

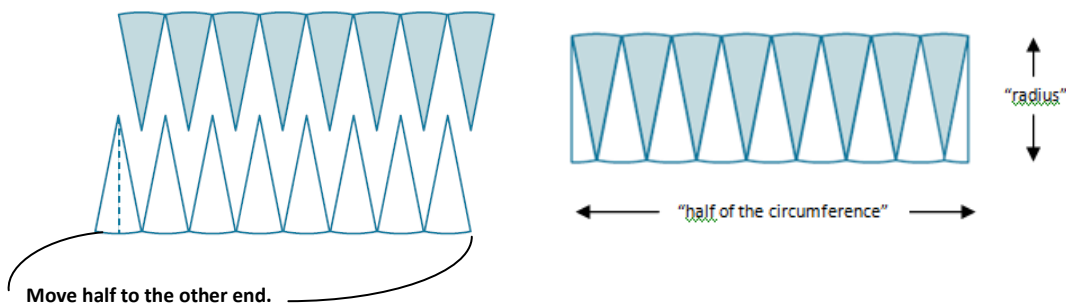

The circumference is $2\pi r$, where the radius is “ r .” Therefore, half of the circumference is πr .

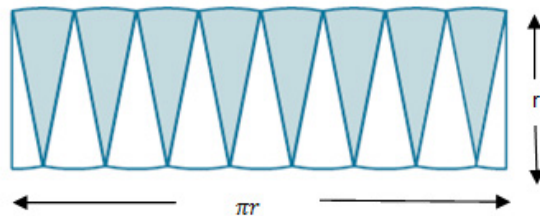

What is the area of the “rectangle” using the side lengths above?

Are the areas of the rectangle and the circle the same?

Yes, since we just rearranged pieces of the circle to make the “rectangle,” the area of the “rectangle” and the area of the circle are approximately equal. Note that the more sections we cut the circle into, the closer the approximation. If the area of the rectangular shape and the circle are the same, what is the area of the circle?

Example 1

Use the shaded square centimeter units to approximate the area of the circle.

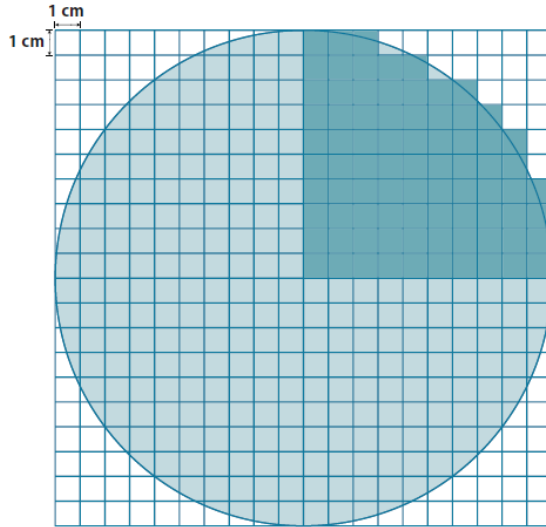

What is the radius of the circle?

What would be a quicker method for determining the area of the circle other than counting all of the squares in the entire circle?

Using the diagram, how many squares did Michael use to cover one-fourth of the circle?

What is the area of the entire circle?

Example 2

A sprinkler rotates in a circular pattern and sprays water over a distance of 12 feet. What is the area of the circular region covered by the sprinkler? Express your answer to the nearest square foot.

Draw a diagram to assist you in solving the problem. What does the distance of 12 feet represent in this problem?

What information is needed to solve the problem?

Example 3

Suzanne is making a circular table out of a square piece of wood. The radius of the circle that she is cutting is 3 feet. How much waste will she have for this project? Express your answer to the nearest square foot.

Draw a diagram to assist you in solving the problem. What does the distance of 3 feet represent in this problem?

What information is needed to solve the problem?

Does your solution answer the problem as stated?

Exercises

4. A circle has a radius of 2 cm.
- Find the exact area of the circular region.
 - Find the approximate area using 3.14 to approximate π .
5. A circle has a radius of 7 cm.
- Find the exact area of the circular region.
 - Find the approximate area using $\frac{22}{7}$ to approximate π .
 - What is the circumference of the circle?
6. Joan determined that the area of the circle below is $400\pi \text{ cm}^2$. Melinda says that Joan's solution is incorrect; she believes that the area is $100\pi \text{ cm}^2$. Who is correct and why?

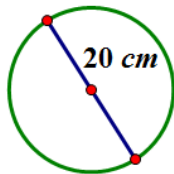
**Relevant Vocabulary**

Circular Region (or Disk): Given a point C in the plane and a number $r > 0$, the *circular region (or disk) with center C and radius r* is the set of all points in the plane whose distance from the point C is less than or equal to r .

The boundary of a disk is a circle. The “area of a circle” refers to the area of the disk defined by the circle.

Problem Set

1. The following circles are not drawn to scale. Find the area of each circle. (Use $\frac{22}{7}$ as an approximation for π .)

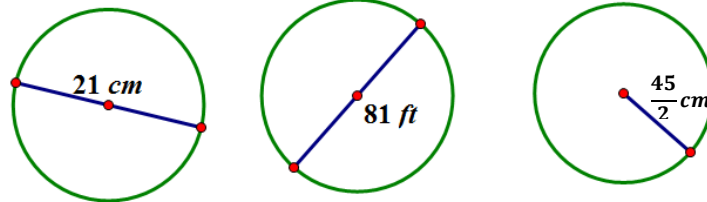

2. A circle has a diameter of 20 inches.
- Find the exact area and find an approximate area using ≈ 3.14 .
 - What is the circumference of the circle using $\pi \approx 3.14$?
3. A circle has a diameter of 11 inches.
- Find the exact area and an approximate area using ≈ 3.14 .
 - What is the circumference of the circle using $\pi \approx 3.14$?
4. Using the figure below, find the area of the circle.

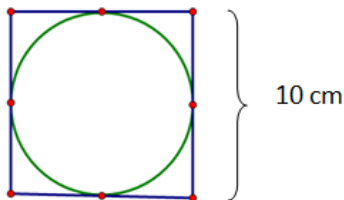

5. A path bounds a circular lawn at a park. If the path is 132 ft. around, approximate the amount of area of the lawn inside the circular path. Use $\pi \approx \frac{22}{7}$.
6. The area of a circle is $36\pi \text{ cm}^2$. Find its circumference.
7. Find the ratio of the area of two circles with radii 3 cm and 4 cm.
8. If one circle has a diameter of 10 cm and a second circle has a diameter of 20 cm, what is the ratio between the areas of the circular regions?
9. Describe a rectangle whose perimeter is 132 ft. and whose area is less than 1 ft^2 . Is it possible to find a circle whose circumference is 132 ft. and whose area is less than 1 ft^2 ? If not, provide an example or write a sentence explaining why no such circle exists.
10. If the diameter of a circle is double the diameter of a second circle, what is the ratio of area of the first circle to the area of the second?

Lesson 18: More Problems on Area and Circumference

Classwork

Opening Exercise

Draw a circle of diameter **12** cm and a square of side length **12** cm on grid paper. Determine the area of the square and the circle.

Brainstorm some methods for finding half the area of the square and half the area of the circle.

Find the area of half of the square and half of the circle, and explain to a partner how you arrived at the area.

What is the ratio of the new area to the original area for the square and for the circle?

Find the area of one-fourth of the square and the circle, first by folding and then by another method. What is the ratio of the new area to the original area for the square and for the circle?

Write an algebraic expression that will express the area of a semicircle and the area of a quarter circle.

Example 1

Find the area of the following semicircle.

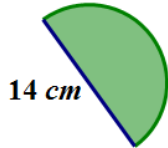

What is the area of the quarter circle?

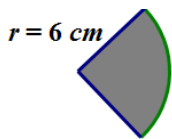

Example 2

Marjorie is designing a new set of placemats for her dining room table. She sketched a drawing of the placement on graph paper. The diagram represents the area of the placemat consisting of a rectangle and two semicircles at either end. Each square on the grid measures 4 inches in length.

Find the area of the entire placemat. Explain your thinking regarding the solution to this problem.

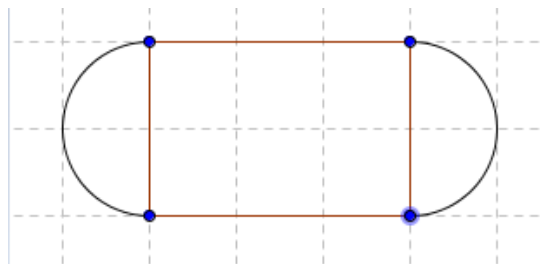

If Marjorie wants to make six placemats, how many square inches of fabric will she need?

Marjorie decides that she wants to sew on a contrasting band of material around the edge of the placemats. How much binding material will Marjorie need?

Example 3

The circumference of a circle is 24π cm. What is the exact area of the circle?

Draw a diagram to assist you in solving the problem.

What information is needed to solve the problem?

Next, find the area.

Exercises

1. Find the area of a circle with a diameter of 42 cm. Use $\pi \approx \frac{22}{7}$.

2. The circumference of a circle is 9π cm.
- What is the diameter?
 - What is the radius?
 - What is the area?
3. If students only know the radius of a circle, what other measures could they determine? Explain how students would use the radius to find the other parts.

4. Find the area in the rectangle between the two quarter circles if $AF = 7$ ft., $FB = 9$ ft., and $HD = 7$ ft. Use $\pi \approx \frac{22}{7}$.

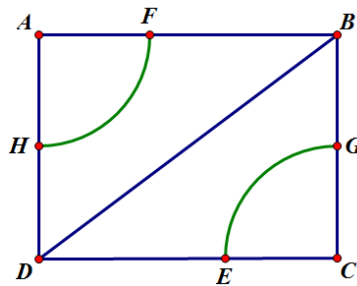

Problem Set

1. Mark created a flowerbed that is semicircular in shape, as shown in the image. The diameter of the flower bed is 5 m.
 - a. What is the perimeter of the flower bed? (Approximate π to be 3.14.)
 - b. What is the area of the flowerbed? (Approximate π to be 3.14.)

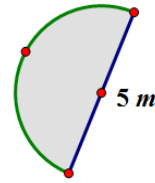

2. A landscape designer wants to include a semicircular patio at the end of a square sandbox. She knows that the area of the semicircular patio is 25.12 cm^2 .
 - a. Draw a picture to represent this situation.
 - b. What is the length of the side of the square?
3. A window manufacturer designed a set of windows for the top of a two story wall. If the window is comprised of two squares and two quarter circles on each end, and if the length of the span of windows across the bottom is 12 feet, approximately how much glass will be needed to complete the set of windows?

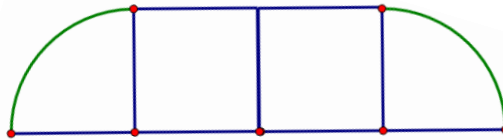

4. Find the area of the shaded region. (Approximate π to be $\frac{22}{7}$.)

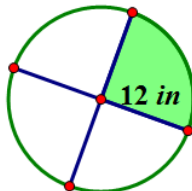

5. The figure below shows a circle inside of a square. If the radius of the circle is 8 cm, find the following and explain your solution.

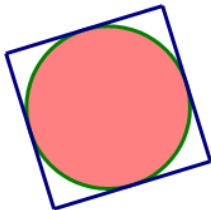

- a. The circumference of the circle.
- b. The area of the circle.
- c. The area of the square.

6. Michael wants to create a tile pattern out of three quarter circles for his kitchen backsplash. He will repeat the three quarter circles throughout the pattern. Find the area of the tile pattern that Michael will use. Approximate π as 3.14.



7. A machine shop has a square metal plate with sides that measure 4 cm each; a machinist must cut four semicircles and four quarter circles, each of radius 1 cm, from its sides and corners. What is the area of the plate formed? Use $\frac{22}{7}$ to approximate π .

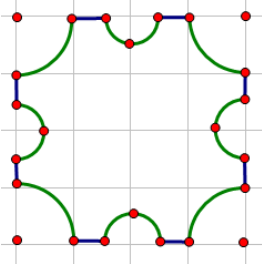

8. A graphic artist is designing a company logo with two concentric circles (two circles that share the same center but have different length radii). The artist needs to know the area of the shaded band between the two concentric circles. Explain to the artist how he would go about finding the area of the shaded region.

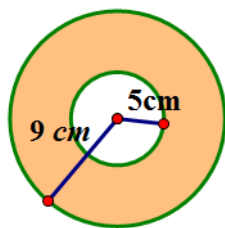

9. Create your own shape made up of rectangles, squares, circles or semicircles and determine the area and perimeter.

Lesson 19: Unknown Area Problems on the Coordinate Plane

Classwork

Example: Area of a Parallelogram

The coordinate plane below contains figure P , parallelogram $ABCD$.

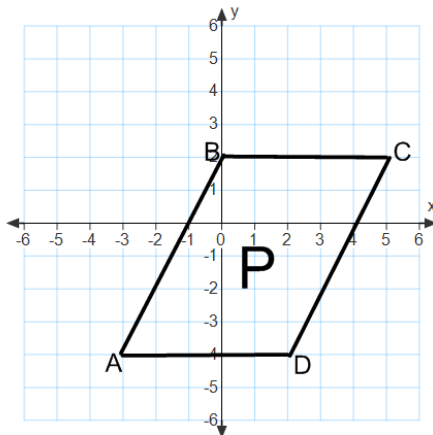

- Write the ordered pairs of each of the vertices next to the vertex points.
- Draw a rectangle surrounding figure P that has vertex points of A and C . Label the two triangles in the figure as S and T .
- Find the area of the rectangle.
- Find the area of each triangle.
- Use these areas to find the area of parallelogram $ABCD$.

The coordinate plane below contains figure R , a rectangle with the same base as the parallelogram above.

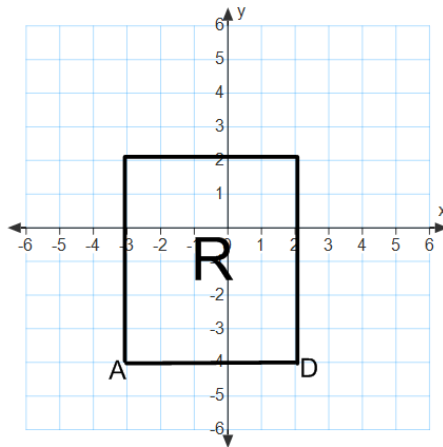

f. Draw triangles S and T next to R so that you have a rectangle that is the same size as the one you created on the first coordinate plane.

g. Find the area of rectangle R .

h. What do figures R and P have in common?

Exercises

1. Find the area of triangle ABC .

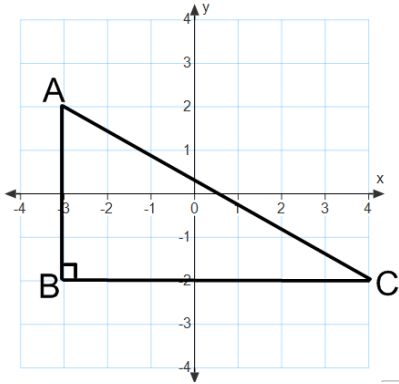

2. Find the area of quadrilateral $ABCD$ two different ways.



3. The area of quadrilateral $ABCD = 12$ sq. units. Find x .

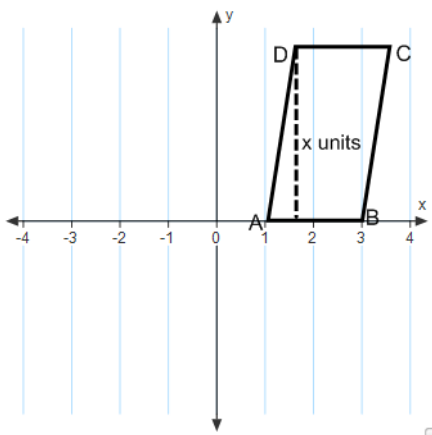

4. The area of triangle $ABC = 14$ sq. units. Find the length of side BC .

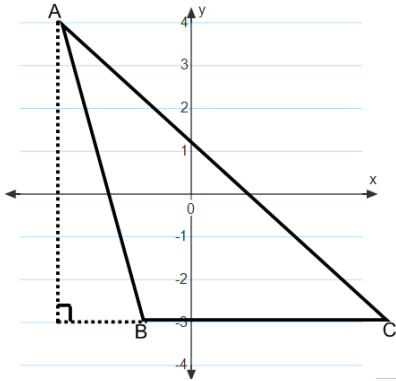

5. Find the area of triangle ABC .

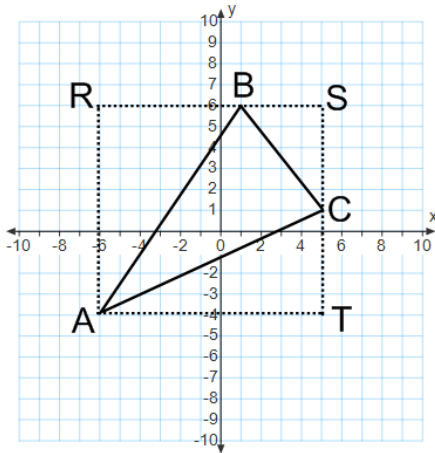

Problem Set

Find the area of each figure.

1.

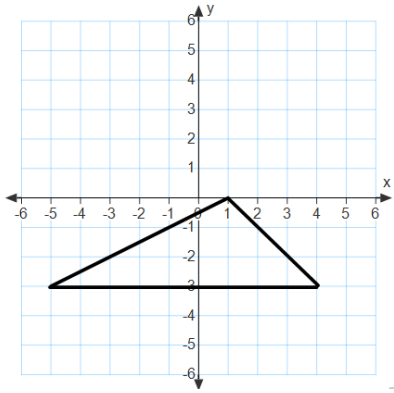

2.

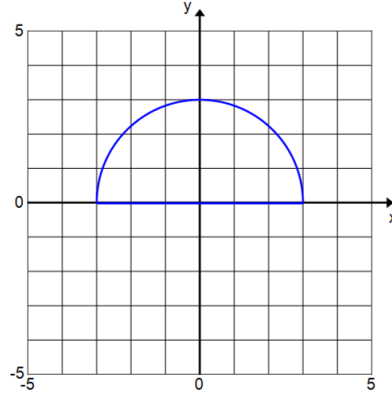

3.

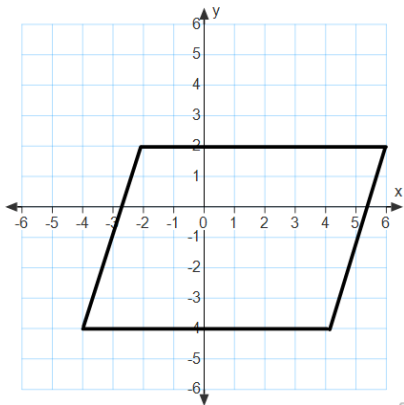

4.

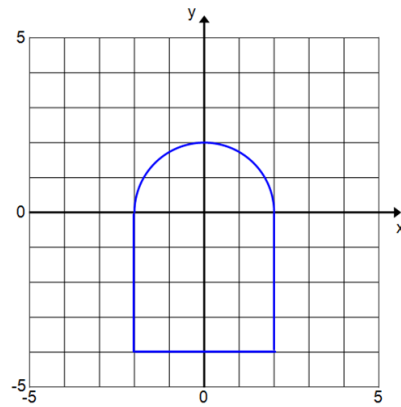

5.

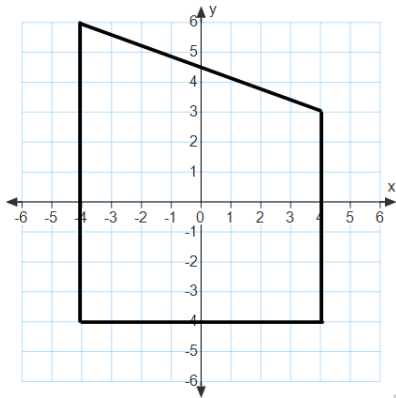

6.

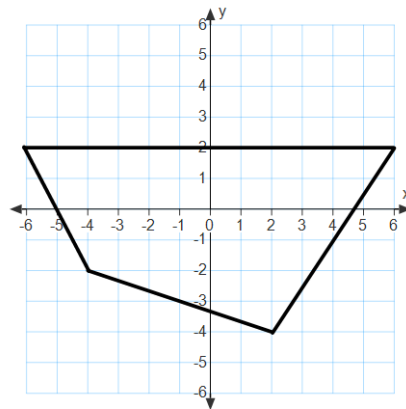

For problems 7–9, draw a figure in the coordinate plane that matches each description.

7. A rectangle with area = 18 sq. units

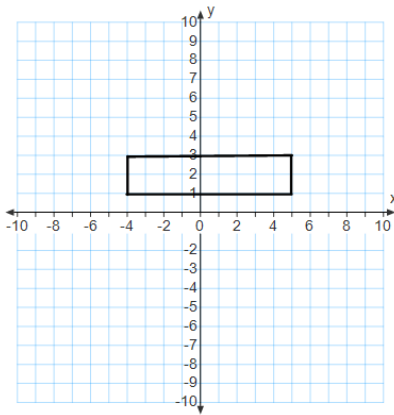

8. A parallelogram with area = 50 sq. units

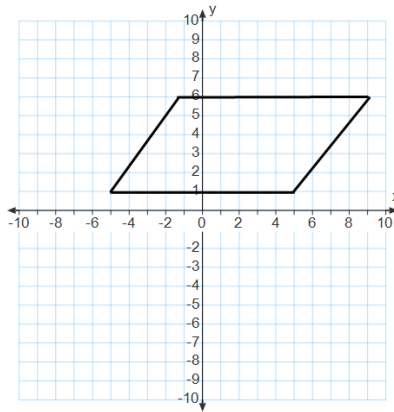

9. A triangle with area = 25 sq. units

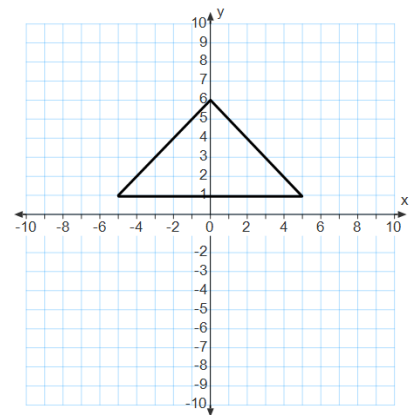

Find the unknown value labelled as x on each figure.

10. The rectangle has an area of 80 sq. units.

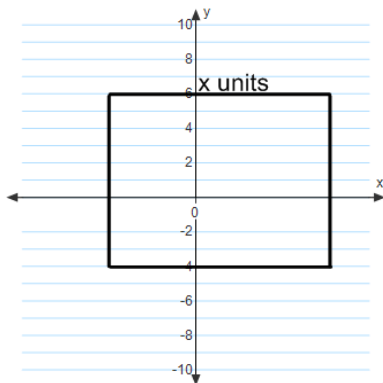

11. The trapezoid has an area of 115 sq. units.

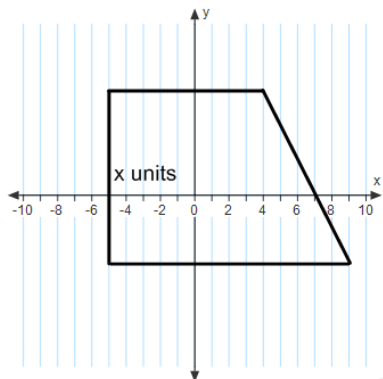

12. Find the area of triangle ABC.

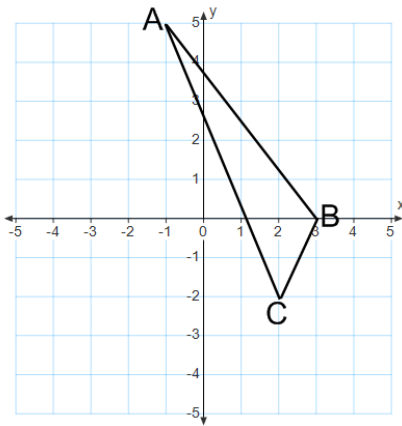

13. Find the area of the quadrilateral using two different methods. Describe the methods used and explain why they result in the same area.

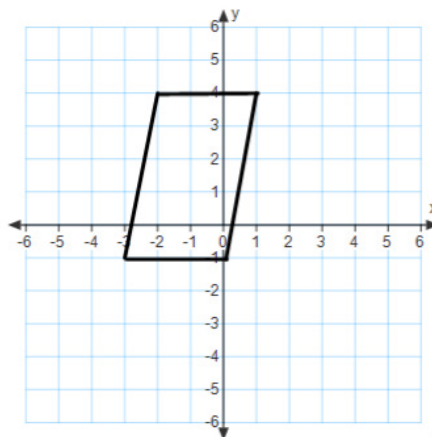

14. Find the area of the quadrilateral using two different methods. What are the advantages or disadvantages of each method?

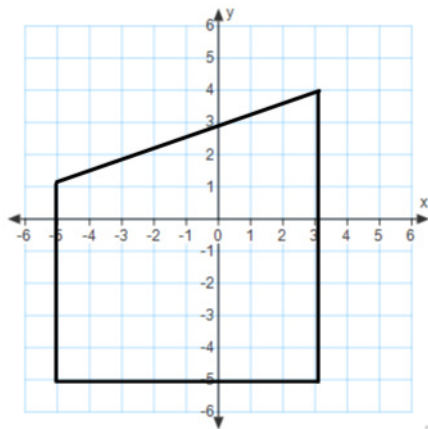

Lesson 20: Composite Area Problems

Classwork

Example 1

Find the composite area of the shaded region. Use 3.14 for π .

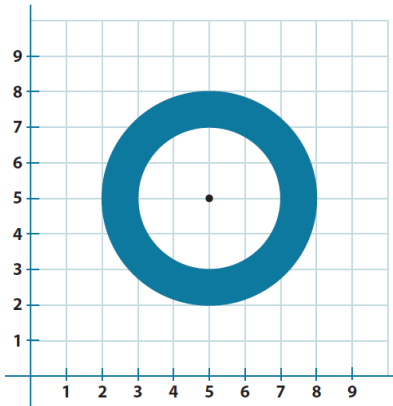

Exercise 1

A yard is shown with the shaded section indicating grassy areas and the unshaded sections indicating buildings or paved areas. Find the area of the space covered with grass in units².

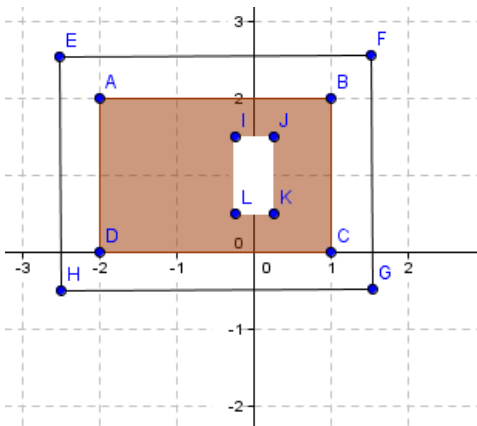

Example 2

Find the area of the figure which consists of a rectangle with a semicircle on top. Use 3.14 for π .

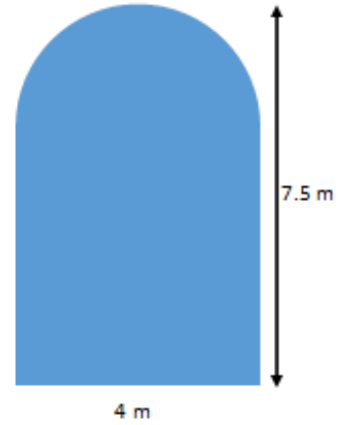

Exercise 2

Find the area of the shaded region using $\pi \approx 3.14$.

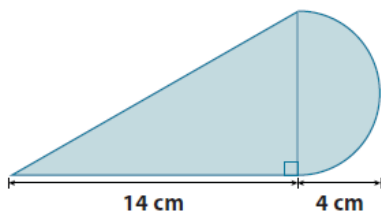

Example 3

Find the area of the shaded region.

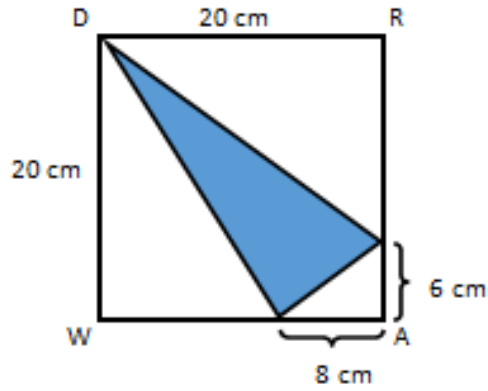

Redraw the figure separating the triangles; then, label the lengths discussing the calculations.

Exercise 3

Find the area of the shaded region.

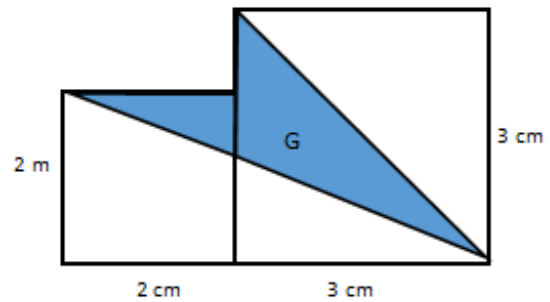

Problem Set

1. Find the area of the shaded region. Use 3.14 for π .

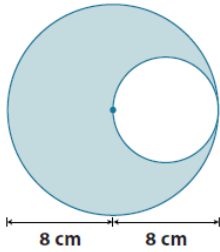

2. The figure shows two semicircles. Find the area of the shaded region. Use 3.14 for π .

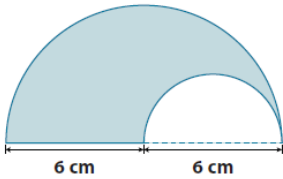

3. The figure shows a semicircle and a square. Find the area of the shaded region. Use 3.14 for π .

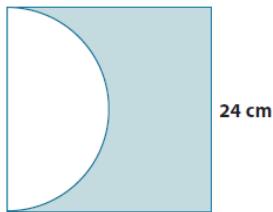

4. The figure shows two semicircles and a quarter of a circle. Find the area of the shaded region. Use 3.14 for π .

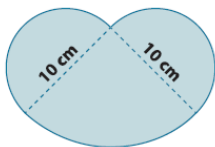

5. Jillian is making a paper flower motif for an art project. The flower she is making has four petals; one of the petals is formed by three semicircles, which is shown below. What is the area of the paper flower?

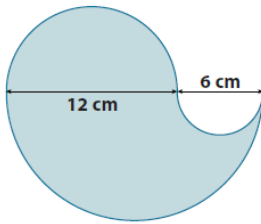

6. The figure is formed by five rectangles. Find the area of the unshaded rectangular region.

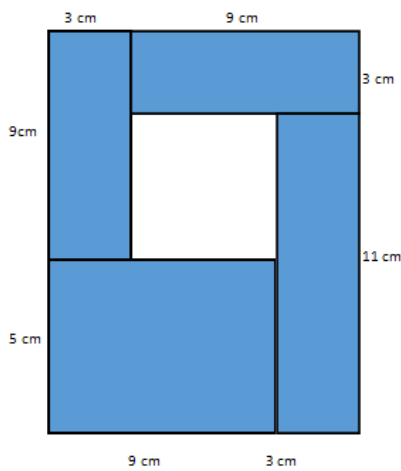

7. The smaller squares in the shaded region each have side lengths of 1.5 m. Find the area of the shaded region.

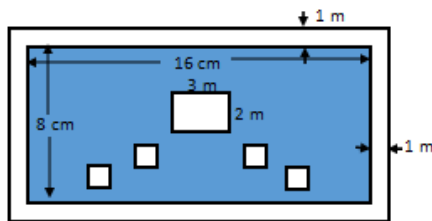

8. Find the area of the shaded region.

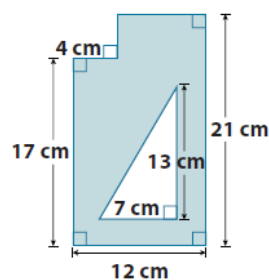

9. a. Find the area of the shaded region.

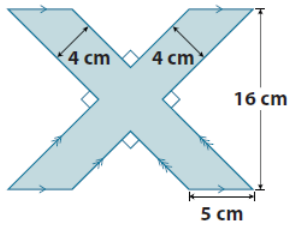

- b. Draw two ways the figure above can be divided in four equal parts.

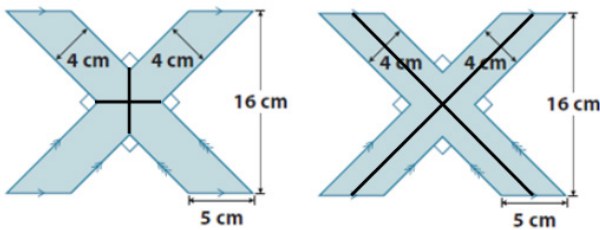

- c. What is the area of one of the parts in (b)?

10. The figure is a rectangle made out of triangles. Find the area of the shaded region.

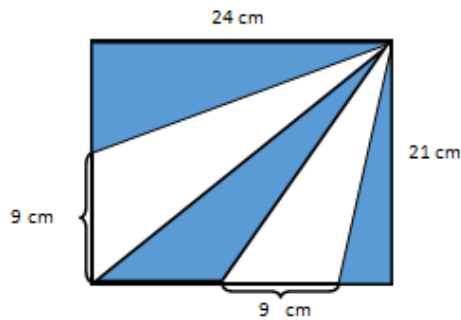

11. The figure consists of a right triangle and an eighth of a circle. Find the area of the shaded region. Use $\frac{22}{7}$ for π .

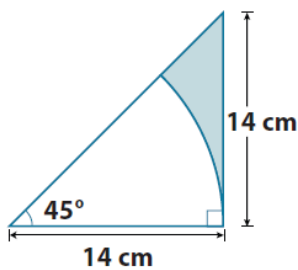

Lesson 21: Surface Area

Classwork

Opening Exercise: Surface Area of a Right Rectangular Prism

On the provided grid, draw a net representing the surfaces of the right rectangular prism (assume each grid line represents 1 inch). Then find the surface area of the prism by finding the area of the net.

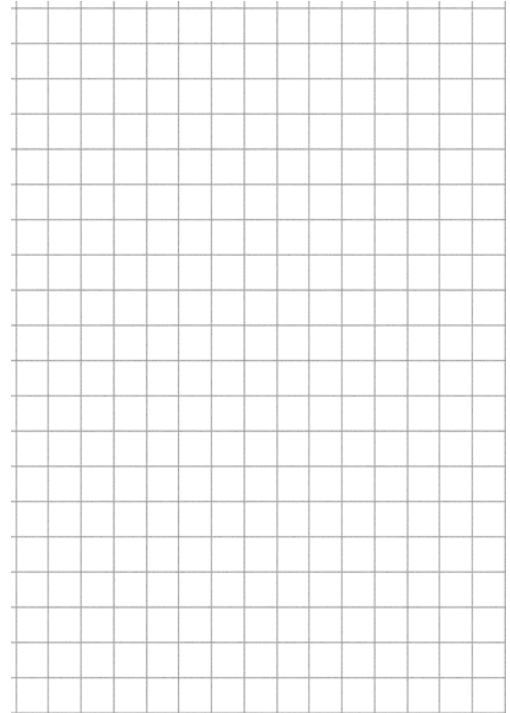

Exercise 1

Marcus thinks that the surface area of the right triangular prism will be half that of the right rectangular prism and wants to use the modified formula $SA = \frac{1}{2}(2lw + 2lh + 2wh)$. Do you agree or disagree with Marcus? Use nets of the prisms to support your argument.

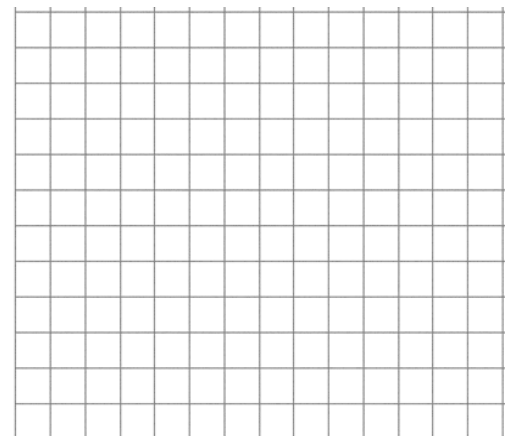

Example 1: Lateral Area of a Right Prism

A right triangular prism, a right rectangular prism, and a right pentagonal prism are pictured below, and all have equal heights of h .

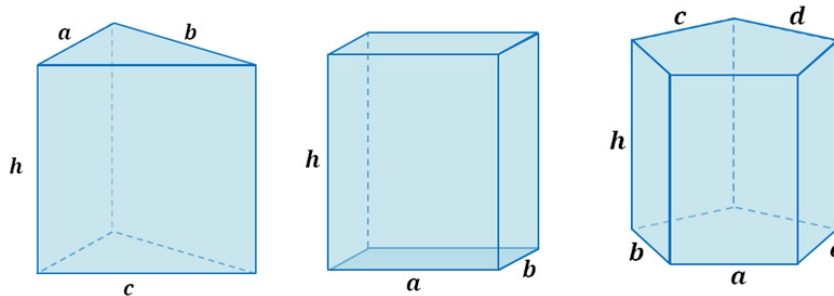

- Write an expression that represents the lateral area of the right triangular prism as the sum of the areas of its lateral faces.
- Write an expression that represents the lateral area of the right rectangular prism as the sum of the areas of its lateral faces.
- Write an expression that represents the lateral area of the right pentagonal prism as the sum of the areas of its lateral faces.
- What value appears often in each expression and why?
- Rewrite each expression in factored form using the distributive property and the height of each lateral face.
- What do the parentheses in each case represent with respect to the right prisms?
- How can we generalize the lateral area of a right prism into a formula that applies to all right prisms?

Relevant Vocabulary

Right Prism: Let E and E' be two parallel planes. Let B be a triangular or rectangular region or a region that is the union of such regions in the plane E . At each point P of B , consider the segment PP' perpendicular to E , joining P to a point P' of the plane E' . The union of all these segments is a solid called a *right prism*.

There is a region B' in E' that is an exact copy of the region B . The regions B and B' are called the base faces (or just bases) of the prism. The rectangular regions between two corresponding sides of the bases are called lateral faces of the prism. In all, the boundary of a right rectangular prism has 6 faces: 2 base faces and 4 lateral faces. All adjacent faces intersect along segments called edges (base edges and lateral edges).

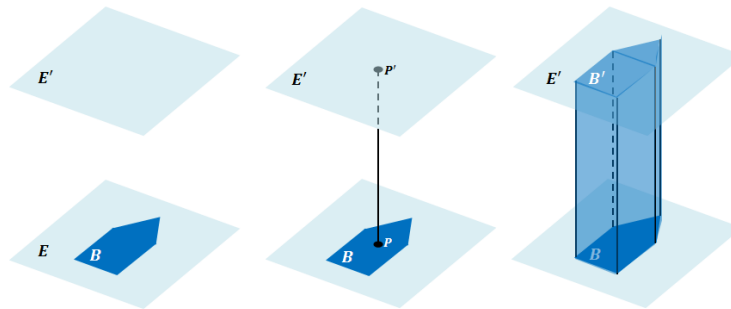

Cube: A *cube* is a right rectangular prism all of whose edges are of equal length.

Surface: The *surface of a prism* is the union of all of its faces (the base faces and lateral faces).

Net (description): A *net* is a two dimensional diagram of the surface of a prism.

1. Why are the lateral faces of right prisms always rectangular regions?
2. What is the name of the right prism whose bases are rectangles?
3. How does this definition of right prism include the interior of the prism?

Lesson Summary

The surface area of a right prism can be obtained by adding the areas of the lateral faces to the area of the bases. The formula for the surface area of a right prism is $SA = LA + 2B$, where SA represents surface area of the prism, LA represents the area of the lateral faces, and B represents the area of one base. The lateral area LA can be obtained by multiplying the perimeter of the base of the prism times the height of the prism.

Problem Set

1. For each of the following nets, highlight the perimeter of the lateral area, draw the solid represented by the net, indicate the type of solid, and then find the solid’s surface area.

a.

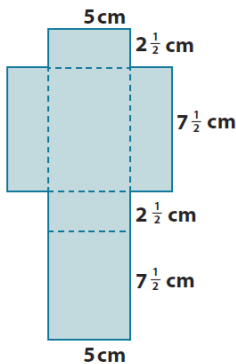

b.

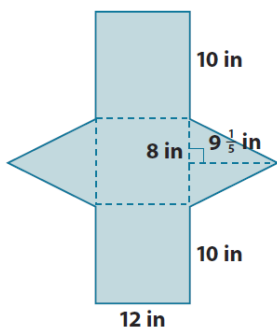

2. Given a cube with edges that are $\frac{3}{4}$ inch long:
- Find the surface area of the cube.
 - Joshua makes a scale drawing of the cube using a scale factor of 4. Find the surface area of the cube that Joshua drew.
 - What is the ratio of the surface area of the scale drawing to the surface area of the actual cube, and how does the value of the ratio compare to the scale factor?

3. Find the surface area of each of the following prisms using the formula $SA = LA + 2B$.

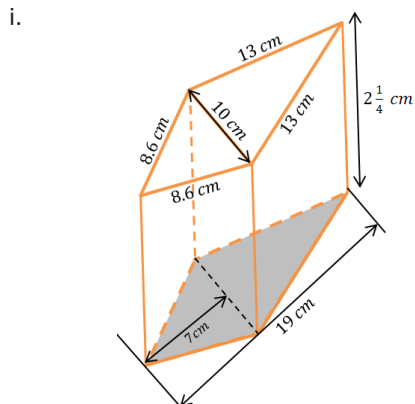
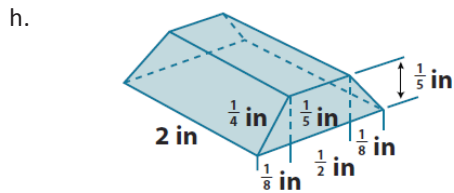
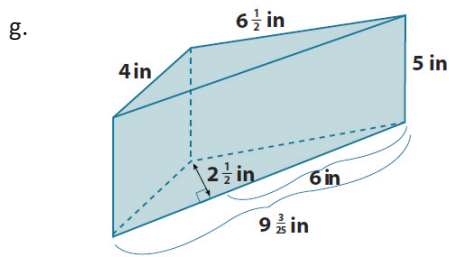
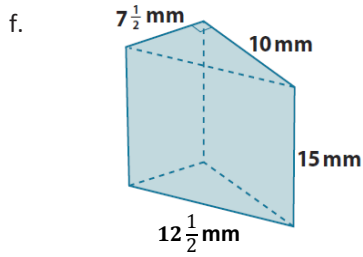

4. A cube has a volume of 64 m^3 . What is the cube's surface area?
5. The height of a right rectangular prism is $4\frac{1}{2}$ ft. The length and width of the prism's base are 2 ft and $1\frac{1}{2}$ ft. Use the formula $SA = LA + 2B$ to find the surface area of the right rectangular prism.
6. The surface area of a right rectangular prism is $68\frac{2}{3} \text{ in}^2$. The dimensions of its base are 3 in and 7 in. Use the formula $SA = LA + 2B$ and $LA = Ph$ to find the unknown height h of the prism.
7. A given right triangular prism has an equilateral triangular base. The height of that equilateral triangle is approximately 7.1 cm. The distance between the bases is 9 cm. The surface area of the prism is $319\frac{1}{2} \text{ cm}^2$. Find the lengths of the sides of the base.

Lesson 22: Surface Area

Classwork

Opening Exercise

What is the area of the composite figure in the diagram? Is the diagram a net for a three-dimensional image? If so, sketch the image. If not, explain why.

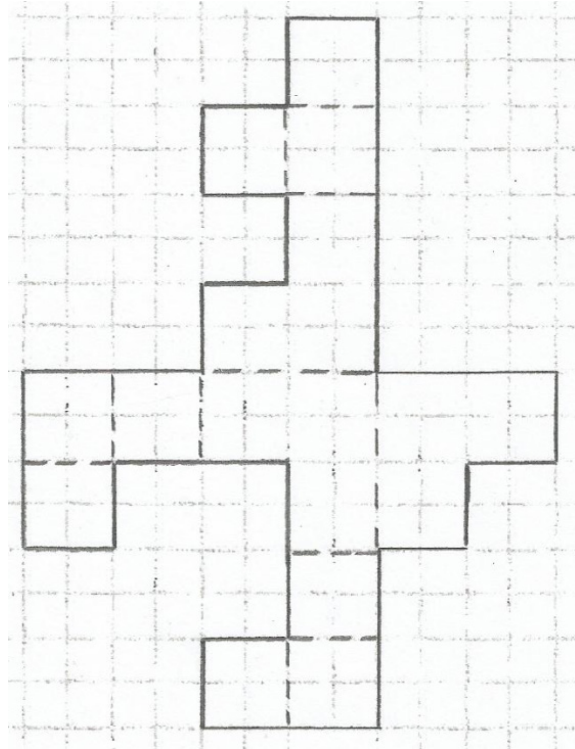

Example 1

The pyramid in the picture has a square base, and its lateral faces are triangles that are exact copies of one another. Find the surface area of the pyramid.

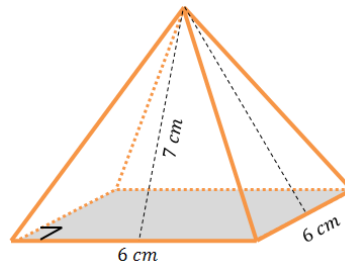

Example 2: Using Cube

There are 13 cubes glued together forming the solid in the diagram. The edges of each cube are $\frac{1}{4}$ inch in length. Find the surface area of the solid.

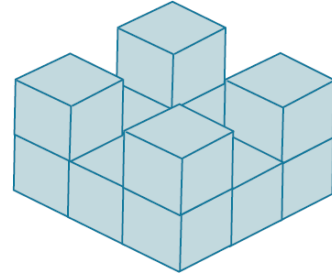

Example 3

Find the total surface area of the wooden jewelry box. The sides and bottom of the box are all $\frac{1}{4}$ inch thick.

What are the faces that make up this box?

How does this box compare to other objects that you have found the surface area of?

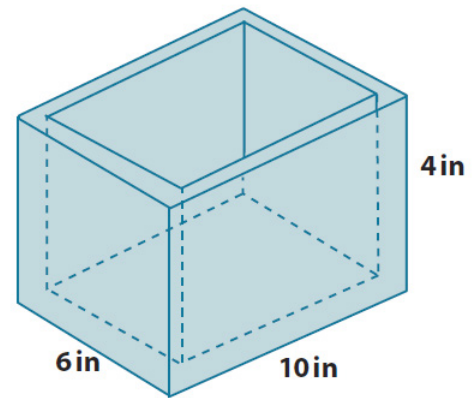

Large Prism

Small Prism

Surface area of the box:

Problem Set

1. For each of the following nets, draw (or describe) the solid represented by the net and find its surface area.

a. The equilateral triangles are exact copies.

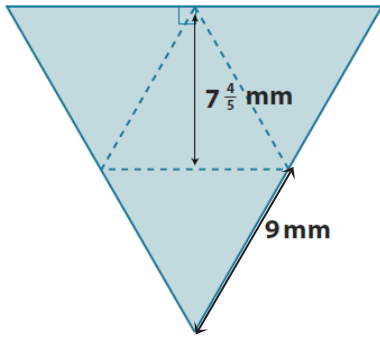

b.

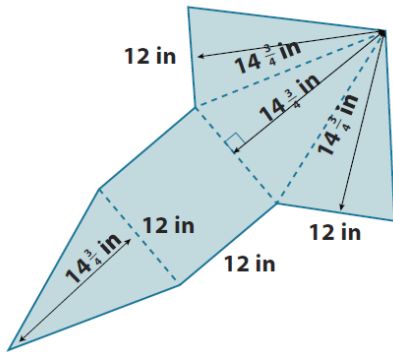

2. Find the surface area of the following prism.

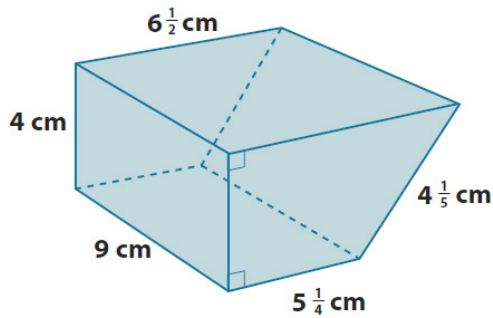

6. Find the surface area of the solid shown in the diagram. The solid is a right triangular prism (with right triangular bases) with a smaller right triangular prism removed from it.

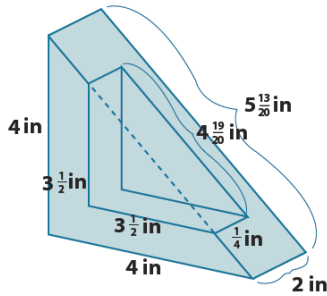

7. The diagram shows a cubic meter that has had three square holes punched completely through the cube on three perpendicular axes. Find the surface area of the remaining solid.

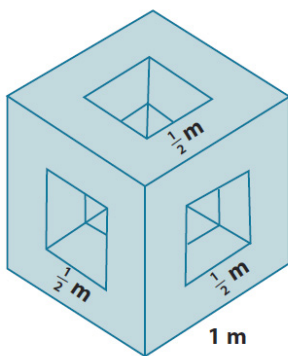

- d. How are figures (b) and (c) related to figure (a)?
6. Find the surface area of the solid shown in the diagram. The solid is a right triangular prism (with right triangular bases) with a smaller right triangular prism removed from it.

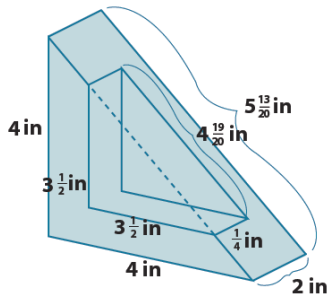

7. The diagram shows a cubic meter that has had three square holes punched completely through the cube on three perpendicular axes. Find the surface area of the remaining solid.

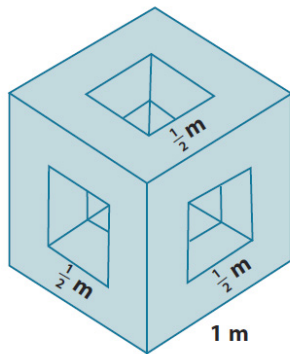

Lesson 23: The Volume of a Right Prism

Classwork

Opening Exercise

The volume of a solid is a quantity given by the number of unit cubes needed to fill the solid. Most solids—rocks, baseballs, people—cannot be filled with unit cubes or assembled from cubes. Yet such solids still have volume. Fortunately, we do not need to assemble solids from unit cubes in order to calculate their volume. One of the first interesting examples of a solid that cannot be assembled from cubes but whose volume can still be calculated from a formula is a right triangular prism.

What is the area of the square pictured on the right? Explain.

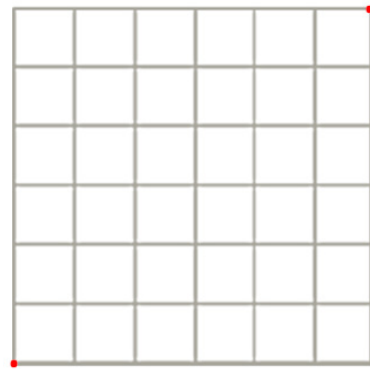

Draw the diagonal joining the two given points then darken the grid lines within the lower triangular region. What is area of that triangular region? Explain.

Example 1: The Volume of a Right Prism

What is the volume of the right prism pictured on the right? Explain.

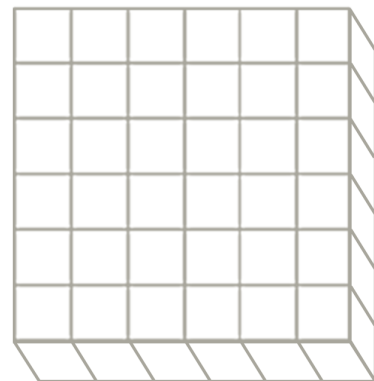

Draw the same diagonal on the square base as done above then darken the grid lines on the lower right triangular prism. What is the volume of that right triangular prism? Explain.

How could we create a right triangular prism with five times the volume of the right triangular prism pictured to the right, without changing the base? Draw your solution on the diagram, give the volume of the solid, and explain why your solution has five times the volume of the triangular prism.

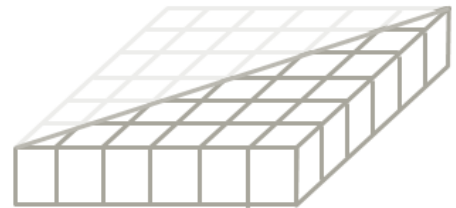

What could we do to cut the volume of the right triangular prism pictured on the right in half without changing the base? Draw your solution on the diagram, give the volume of the solid, and explain why your solution has half the volume of the given triangular prism.

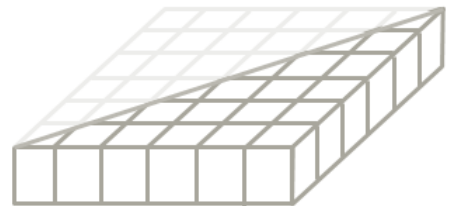

To find the volume (V) of any right prism...

Example 2: The Volume of a Right Triangular Prism

Find the volume of the right triangular prism shown in the diagram using $V = Bh$.

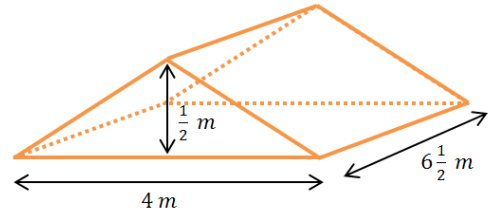

Exercise 1: Multiple Volume Representations

The right pentagonal prism is composed of a right rectangular prism joined with a right triangular prism. Find the volume of the right pentagonal prism shown in the diagram using two different strategies.

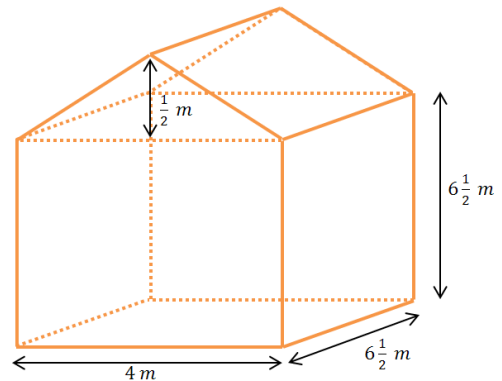

Problem Set

1. Calculate the volume of each solid using the formula $V = Bh$ (all angles are 90 degrees):

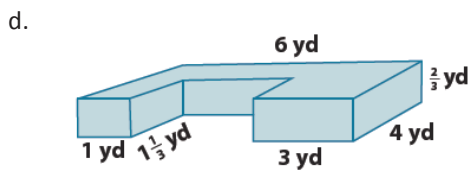
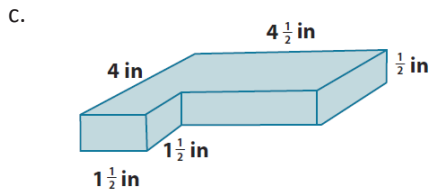
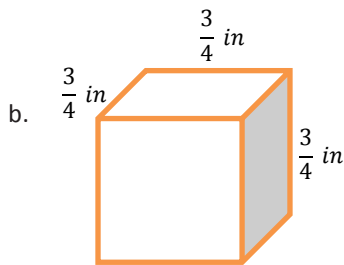
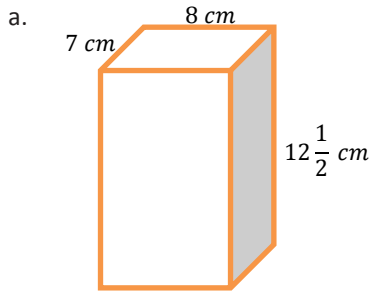

e.

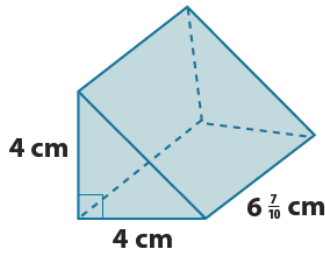

f.

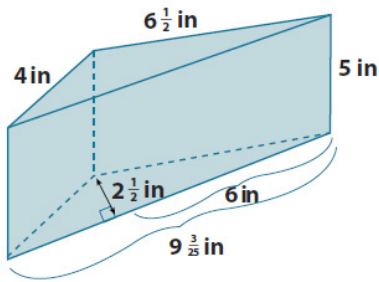

g.

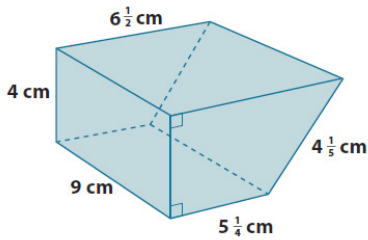

h.

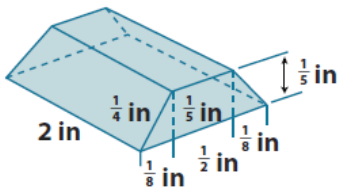

2. Let L represent length, W the width, and H the height of a right rectangular prism. Find the volume of the prism when:

a. $L = 3 \text{ cm}$, $W = 2\frac{1}{2} \text{ cm}$, and $H = 7 \text{ cm}$

b. $L = \frac{1}{4} \text{ cm}$, $W = 4 \text{ cm}$, and $H = 1\frac{1}{2} \text{ cm}$

3. Find the length of the edge indicated in each diagram.

a.

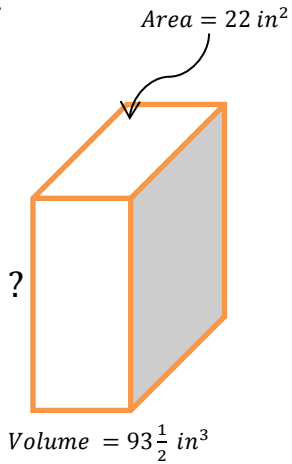

What are possible dimensions of the base?

b.

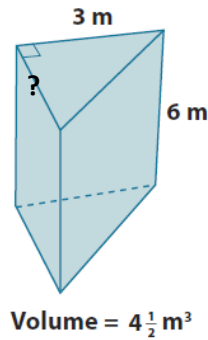

4. The volume of a cube is $3\frac{3}{8} \text{ in}^3$. Find the length of each edge of the cube.

5. Given a right rectangular prism with a volume of $7\frac{1}{2} \text{ ft}^3$, a length of 5 ft , and a width of 2 ft , find the height of the prism.

Lesson 24: The Volume of a Right Prism

Classwork

Example 1: Measuring a Container's Capacity

A box in the shape of a right rectangular prism has a length of 12 in., a width of 6 in., and a height of 8 in. The base and the walls of the container are $\frac{1}{4}$ in. thick, and its top is open. What is the capacity of the right rectangular prism? (Hint: The capacity is equal to the volume of water needed to fill the prism to the top.)

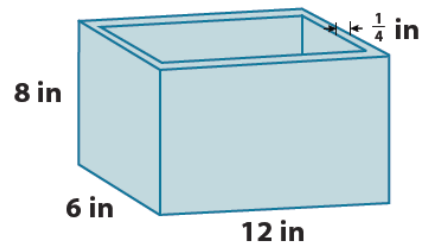

Example 2 (5 minutes): Measuring Liquid in a Container in Three Dimensions

A glass container is in the form of a right rectangular prism. The container is 10 cm long, 8 cm wide, and 30 cm high. The top of the container is open and the base and walls of the container are 3 mm (or 0.3 cm) thick. The water in the container is 6 cm from the top of the container. What is the volume of the water in the container?

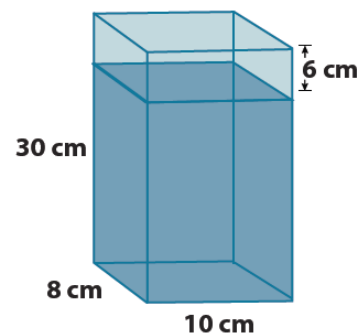

Example 3

7.2 L of water are poured into a container in the shape of a right rectangular prism. The inside of the container is 50 cm long, 20 cm wide, and 25 cm tall. How far from the top of the container is the surface of the water? (1 L = 1000 cm³)

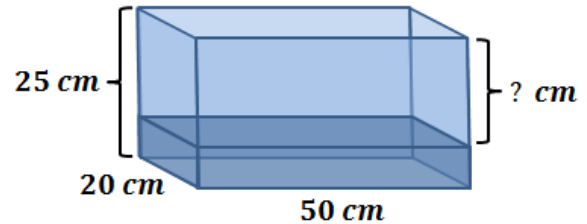
**Example 4**

A fuel tank is the shape of a right rectangular prism and has 27 L of fuel in it. It is determined that the tank is $\frac{3}{4}$ full. The inside dimensions of the base of the tank are 90 cm by 50 cm. How deep is the fuel in the tank? How deep is the tank? (1 L = 1000 cm³)

Problem Set

1. Mark wants to put some fish and some decorative rocks in his new glass fish tank. He measured the outside dimensions of the right rectangular prism and recorded a length of 55 cm, width of 42 cm, and height of 38 cm. He calculates that the tank will hold 87.78 L of water. Why is Mark's calculation of volume incorrect? What is the correct volume? Mark also failed to take into account the fish and decorative rocks he plans to add. How will this affect the volume of water in the tank? Explain.
2. Leondra bought an aquarium that is a right rectangular prism. The inside dimensions of the aquarium are 90 cm long, by 48 cm wide, by 60 cm deep. She plans to put water in the aquarium before purchasing any pet fish. How many liters of water does she need to put in the aquarium so that the water level is 5 cm below the top?
3. The inside space of two different water tanks are shown below. Which tank has a greater capacity? Justify your answer.

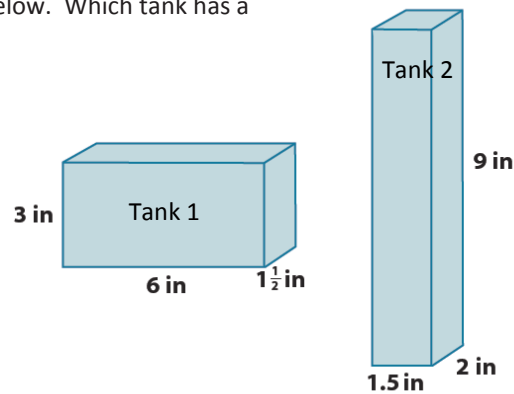

4. The inside of a tank is in the shape of a right rectangular prism. The base of that prism is 85 cm by 64 cm. What is the minimum height inside the tank if the volume of the liquid in the tank is 92 L?
5. An oil tank is the shape of a right rectangular prism. The inside of the tank is 36.5 cm long, 52 cm wide, and 29 cm high. If 45 liters of oil have been removed from the tank since it was full, what is the current depth of oil left in the tank?
6. The inside of a right rectangular prism-shaped tank has a base that is 14 cm by 24 cm and a height of 60 cm. The tank is filled to its capacity with water, then 10.92 L of water is removed. How far did the water level drop?
7. A right rectangular prism-shaped container has inside dimensions of $7\frac{1}{2}$ cm long and $4\frac{3}{5}$ cm wide. The tank is $\frac{3}{5}$ full of vegetable oil. It contains 0.414 liters of oil. Find the height of the container.
8. A right rectangular prism with length of 10 in., width of 16 in., and height of 12 in. is $\frac{2}{3}$ filled with water. If the water is emptied into another right rectangular prism with a length of 12 in., a width of 12 in., and height of 9 in., will the second container hold all the water? Explain why or why not. Determine how far (above or below) the water level would be from the top of the container.

Lesson 25: Volume and Surface Area

Classwork

Opening Exercise

What is the surface area and volume of the right rectangular prism?

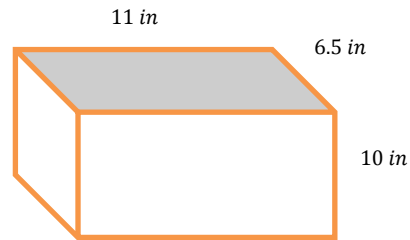

Example 1: Volume of a Fish Tank

Jay has a small fish tank. It is the same shape and size as the right rectangular prism shown in the Opening Exercise.

- The box it came in says that it is a *three* gallon tank. Is this claim true? Explain your reasoning. Recall that $1 \text{ gal} = 231 \text{ in}^3$.
- The pet store recommends filling the tank to within 1.5 inches of the top. How many gallons of water will the tank hold if it is filled to the recommended level?
- Jay wants to cover the back, left, and right sides of the tank with a background picture. How many square inches will be covered by the picture?

- d. Water in the tank evaporates each day, causing the water level to drop. How many gallons of water have evaporated by the time the water in the tank is four inches deep? Assume the tank was filled to within 1.5 inches of the top to start.

Exercise 1: Fish Tank Designs

Two fish tanks are shown below, one in the shape of a right rectangular prism (R) and one in the shape of a right trapezoidal prism (T).

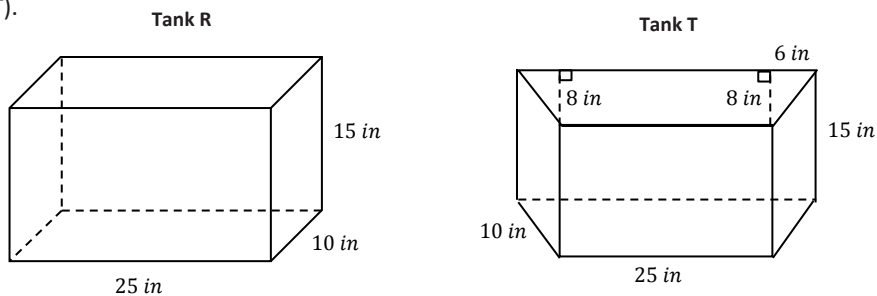

- a. Which tank holds the most water? Let $Vol(R)$ represent the volume of the right rectangular prism and $Vol(T)$ represent the volume of the right trapezoidal prism. Use your answer to fill in the blanks with $Vol(R)$ and $Vol(T)$.

_____ < _____

- b. Which tank has the most surface area? Let $SA(R)$ represent the surface area of the right rectangular prism and $SA(T)$ represent the surface area of the right trapezoidal prism. Use your answer to fill in the blanks with $SA(R)$ and $SA(T)$.

_____ < _____

- c. Water evaporates from each aquarium. After the water level has dropped $\frac{1}{2}$ inch in each aquarium, how many cubic inches of water are required to fill up each aquarium? Show work to support your answers.

Exercise 2: Design Your Own Fish Tank

Design at least three fish tanks that will hold approximately 10 gallons of water. All of the tanks should be shaped like right prisms. Make at least one tank have a base that is not a rectangle. For each tank, make a sketch, and calculate the volume in gallons to the nearest hundredth.

Challenge Problem: Each tank is to be constructed from glass that is $\frac{1}{4}$ in. thick. Select one tank that you designed and determine the difference between the volume of the total tank, including the glass and the volume inside the tank. Do not include a glass top on your tank.

Problem Set

1. The dimensions of several rectangular fish tanks are listed below. Find the volume in cubic centimeters, the capacity in liters, and the surface area in square centimeters for each tank (1 L = 1,000 cm³). What do you observe about the change in volume compared with the change in surface area between the small tank and the extra-large tank?

Tank Size	Length (cm)	Width (cm)	Height (cm)
Small	24	18	15
Medium	30	21	20
Large	36	24	25
Extra Large	40	27	30

Tank Size	Volume (cm ³)	Capacity (l)	Surface Area (cm ²)
Small			
Medium			
Large			
Extra Large			

2. A rectangular container 15 cm long by 25 cm wide contains 2.5 L of water.

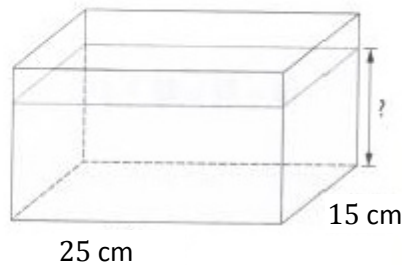

- Find the height of the water level in the container. (1 L = 1,000 cm³)
 - If the height of the container is 18 cm, how many more liters of water would it take to completely fill the container?
 - What percentage of the tank is filled when it contains 2.5 liters of water?
3. A rectangular container measuring 20 cm by 14.5 cm by 10.5 cm is filled with water to its brim. If 300 cm³ are drained out of the container, what will be the height of the water level?

4. Two tanks are shown below. Both are filled to capacity, but the owner decides to drain them. Tank 1 is draining at a rate of 8 liters per minute. Tank 2 is draining at a rate of 10 liters per minute. Which tank empties first?

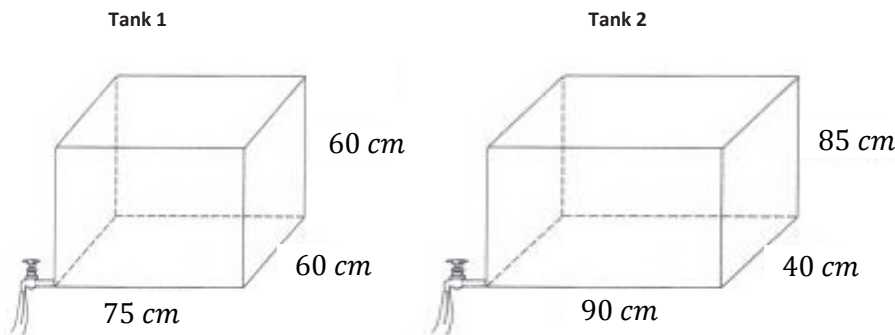

5. Two tanks are shown below. One tank is draining at a rate of 8 liters per minute into the other one, which is empty. After 10 minutes, what will be the height of the water level in the second tank?

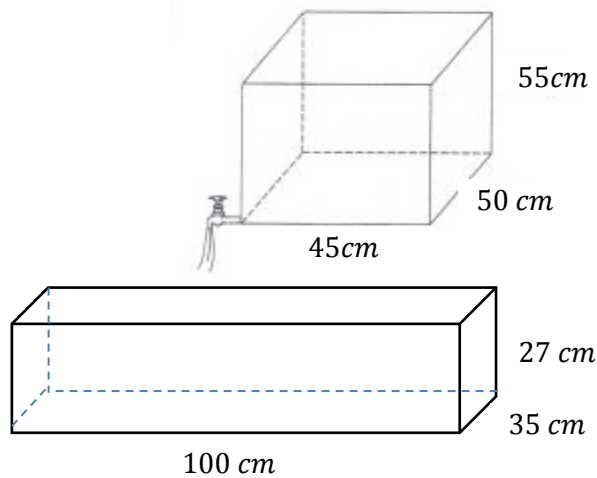

6. Two tanks with equal volumes are shown below. The tops are open. The owner wants to cover one tank with a glass top. The cost of glass is \$0.05 per square inch. Which tank would be less expensive to cover?

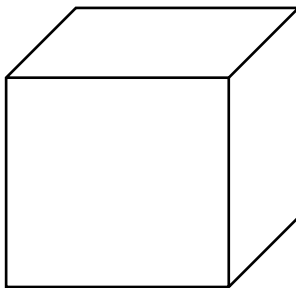

Dimensions: 12 in. long by 8 in. wide by 10 in. high

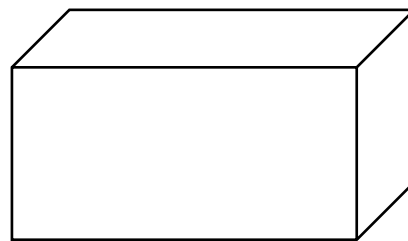

Dimensions: 15 in. long by 8 in. wide by 8 in. high

7. Each prism below is a gift box sold at the craft store.

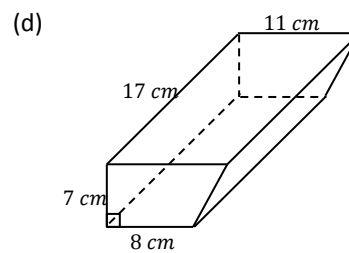
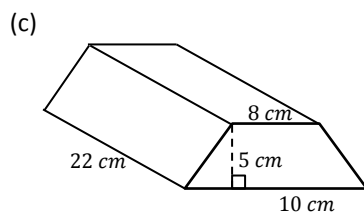
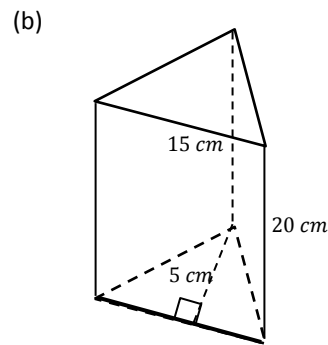
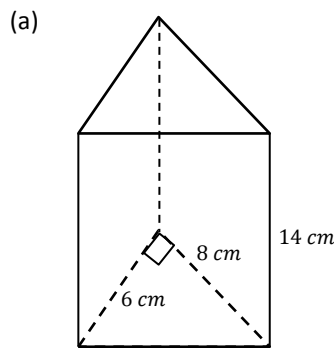

- a. What is the volume of each prism?
 - b. Jenny wants to fill each box with jelly beans. If one ounce of jelly beans is approximately 30 cm^3 , estimate how many ounces of jelly beans Jenny will need to fill all four boxes? Explain your estimates.
8. Two rectangular tanks are filled at a rate of 0.5 cubic inches per minute. How long will it take each tank to be half full?
- a. Tank 1 Dimensions: 15 inches by 10 inches by 12.5 inches
 - b. Tank 2 Dimensions: $2\frac{1}{2}$ in. by $3\frac{3}{4}$ in. by $4\frac{3}{8}$ in.

Lesson 26: Volume and Surface Area

Classwork

Opening Exercise

Explain to your partner how you would calculate the area of the shaded region. Then, calculate the area.

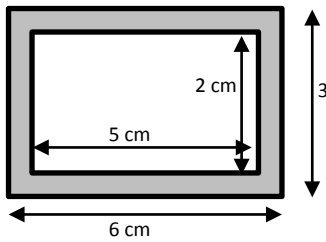

Example 1: Volume of a Shell

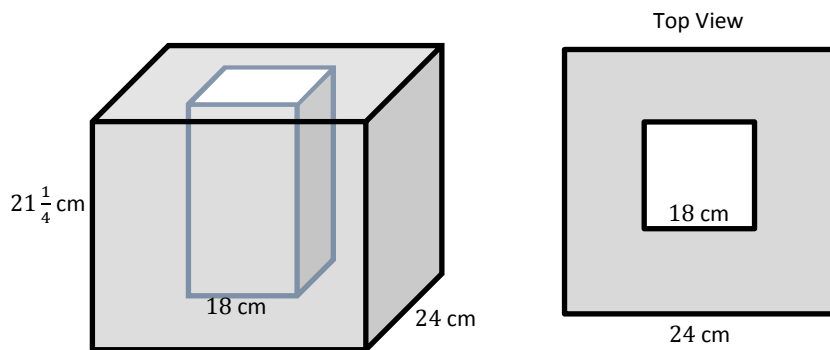

The insulated box shown is made from a large cube with a hollow inside that is a right rectangular prism with a square base. The figure at right is what the box looks like from above.

- Calculate the volume of the outer box.
- Calculate the volume of the inner prism.

- c. Describe in words how you would find the volume of the insulation.
- d. Calculate the volume of the insulation in cubic centimeters.
- e. Calculate the amount of water the box can hold in liters.

Exercise 1: Designing a Brick Planter (10 minutes)

You have been asked by your school to design a brick planter that will be used by classes to plant flowers. The planter will be built in the shape of a right rectangular prism with no bottom so water and roots can access the ground beneath. The exterior dimensions are to be 12 ft. \times 9 ft. \times $2\frac{1}{2}$ ft. The bricks used to construct the planter have are 6 inches long, $3\frac{1}{2}$ inches wide, and 2 inches high.

- a. What are the interior dimensions of the planter if the thickness of the planter's walls is equal to the length of the bricks?
- b. What is the volume all the brick that forms the planter?

- c. If you are going to fill the planter $\frac{3}{4}$ full of soil, how much soil will you need to purchase, and what will be the height of the soil?
- d. How many bricks are needed to construct the planter?
- e. The bricks used in this project cost \$0.82 each and weigh 4.5 lb. each. The supply company charges a delivery fee of \$15 per whole ton (2000 *lbs*) over 4000 pounds. How much will your school pay for the bricks (including delivery) to construct the planter?

- f. A cubic foot of top soil weighs between 75 and 100 lb. How much will the soil in the planter weigh?
- g. If the topsoil costs \$0.88 per each cubic foot, calculate the total cost of materials that will be used to construct the planter.

Exercise 2: Design a Feeder

You did such a good job designing the planter that a local farmer has asked you to design a feeder for the animals on his farm. Your feeder will hold at least 600 cubic centimeters, but not more than 800 cubic centimeters of grain when it is full. It will sit on the ground (don't worry about the base or what holds it up in your design). It will be built of metal that is $2\frac{1}{4}$ cm thick and must be a prism, but not a rectangular prism. Sketch your design below with dimensions. Calculate the volume of grain that it can hold and the amount of metal needed to construct the feeder.

The farmer needs a cost estimate. Calculate the cost of constructing and filling the feeder if grain sells for $\$0.40/\text{cm}^3$ and metal sells for $\$7.50/\text{square meter}$.

Problem Set

1. A child’s toy is constructed by cutting a right triangular prism out of a right rectangular prism.

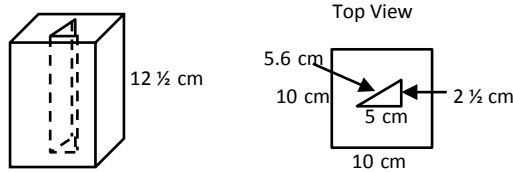

- Calculate the volume of the rectangular prism.
 - Calculate the volume of the triangular prism.
 - Calculate the volume of the material remaining in the rectangular prism.
 - What is the largest number of triangular prisms that can be cut from the rectangular prism?
 - What is the surface area of the triangular prism (assume there is no top or bottom)?
2. A landscape designer is constructing a flower bed in the shape of a right trapezoidal prism. He needs to run three identical square prisms through the bed for drainage.

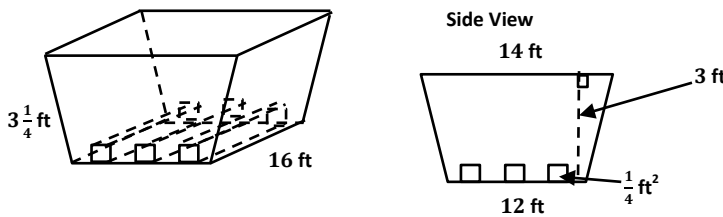

- What is the volume of the bed without the drainage pipes?
- What is the total volume of the three drainage pipes?
- What is the volume of soil that can fit in the bed once the pipes are in place, assuming the amount of soil is filled to $\frac{3}{4}$ of the height of the planter?
- What is the height of the soil?
- If the bed is made of 8 ft \times 4 ft. pieces of plywood, how many pieces of plywood will the landscape designer need to construct the bed without the drainage pipes?
- If the plywood needed to construct the bed costs \$35 per 8 ft. \times 4 ft. piece, the drainage pipes cost \$125 each, and the soil costs \$1.25/cubic foot, how much does it cost to construct and fill the bed?